

# Racal Instruments™

# 1260-14/14C

## Digital I/O Module

The Racal Instruments™ 1260-14 provides 96 TTL, CMOS, or Open-collector channels in twelve groups of eight bits each. With the open collector version each independent group can utilize a separate internal or external pull-up supply up to 32 VDC.

These open collector transistors are ideal for controlling external digital circuitry, switches, relays and similar devices. Each channel is configurable as an input or an output. Channels are individually controlled in asynchronous mode or with other channels in synchronous mode.

### Key Features

- 96 TTL, CMOS or open-collector input/output channels
- Drives up to 32 V and sinks up to 200 mA per channel
- Two-wire programmable hand shaking
- Synchronous, asynchronous and mixed operating modes
- 200 kHz data rate
- Single-slot, C-size, message-based VXIbus module

### Product Information

The 1260-14 has a two-wire handshake mode available for the control of synchronous I/O transactions. Each handshake line can be programmed as either active high or active low providing a flexible interface with user signals.

The 1260-14 is programmable in several operating modes and data may be manipulated in either hex, decimal or binary.

Memory is available on the 1260 Series Smart Card Module to allow buffered I/O operations.

The 1260-14 is also available in TTL or CMOS compatible I/O channels. Each TTL or CMOS I/O channel may be placed in a high impedance, tri-state mode.

The 1260-14 is controlled by the Racal Instruments™ Option 01 message-based interface or the Option 01T message-based and register-based interface. All 1260

control features explained on the Option 01 and Option 01T data sheets are available to this module.

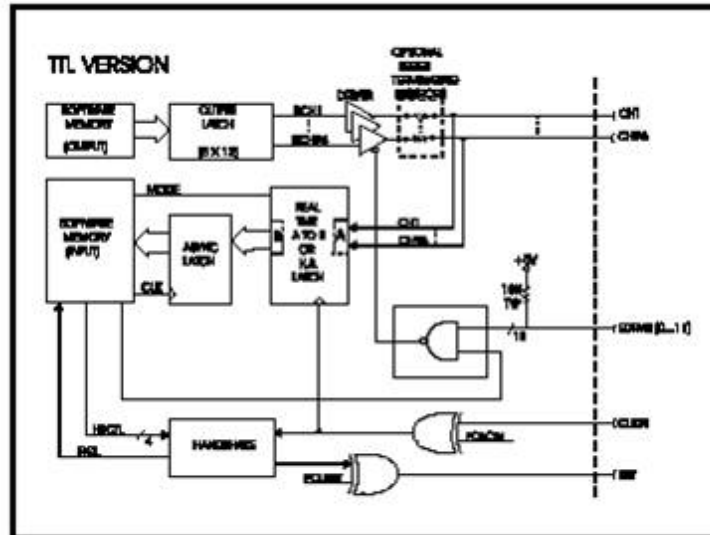

Note: Module is supplied with one set of mating connectors. Additional connectors can be ordered using the part number shown below.

## Specifications

Note: The Astronics Test Systems policy is one of continuous development and improvement. Consequently, the equipment may vary in detail from the description and specifications in this publication.

### Number of Channels

- 96

### Data Rate

- Static to 200 kHz (Asynchronous, Register-Based)
- Static to 800 Hz (Synchronous)

### Operating Modes

- Asynchronous
- Synchronous
- Mixed (Synchronous and Asynchronous)

### Input/Output

- TTL, CMOS, or Open Collector TTL

### Configuration

- I/O lines selected as either input or output on an 8-bit byte basis

Output Voltage	TTL	CMOS	Open Collector
$V_{out}$ (high)	$\geq 2.4$ V @ -15 mA	$\geq 3.8$ V @ 6 mA	$5$ V $\leq V_{on} \leq 32$ V
$V_{out}$ (low)	$\leq 0.5$ V @ 48 mA	$\leq 0.4$ V @ 6 mA	$\leq 1.5$ @ $I_{info}=200$ mA

Input Voltage	TTL	CMOS	Open Collector
$V_{in}$ (high)	$\geq 2.0$ V	$\geq 3.15$ V	$\geq 2.0$ V
$V_{in}$ (low)	$\leq 0.8$ V	$\leq 0.9$ V	$\leq 1.5$ V
$V_{in}$ (max)	5.25 V	5.00 V	32 VDC

## Interface

### Power Requirements ( $I_{PM}$ )

- +5 V: 2.38 A, (if no internal supplies are used to pull up the outputs)
- 4.78 A with Option 01/01T installed

## Mechanical

### Weight

- 2.69 lb (1.21 kg) without Option 01/01T
- 2.97 lb (1.34 kg) with Option 01/01T

## Dimensions

- C-size, Single-slot VXIbus Module

## Cooling Requirements

- Airflow: 1.2 l/s
- Back Pressure: 0.6 mm H<sub>2</sub>O

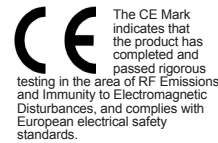

## Ordering Information

Notes: Compatible smart controllers: A smart card must be installed in the left-most slot of a set of 1260-xx series switch cards. There are two options:

- Option 01: Native command set. For use in previously designed switching systems that used the Option 01.
- Option 01T: SCPI command set. For use in new systems and previously designed systems that used the Option 01T.

The 1260-14 is supplied with one set of mating connectors. Additional connectors can be ordered using the part numbers shown below.

### 404916 : Racal Instruments™ 1260-14

Digital I/O Module, TTL Compatible

### 404916-001 : Racal Instruments™ 1260-14 (CMOS)

Digital I/O Module, CMOS Compatible

### 407164 : Racal Instruments™ 1260-14C

Digital I/O Module, Open Collector

## Options and Accessories:

OPT-401901-005 : Racal Instruments™ Option 01, Smart Control Module installed (manual must be ordered separately)

404820-005 : Racal Instruments™ Option 01, Smart Control Module (not installed) with manual

OPT-405108-001 : Racal Instruments™ Option 01T Smart Control Module installed (manual must be ordered separately)

407531-001 : Racal Instruments™ Option 01T Smart Control Module (not installed) with manual

601627 : 50-pin IDC Pin #601627 (2 supplied)

601457 : 60-pin IDC Pin #601457 (2 supplied)



All trademarks and service marks used in this document are the property of their respective owners.

- Racal Instruments is a trademark of Astronics Test Systems Inc. in the United States and/or other countries