

RACAL INSTRUMENTS™
1260-43
1260 VXI SWITCHING CARD
THREE, 8X24 MATRIX, MODULE

Publication No.980673-067 Rev. B

Astronics Test Systems Inc.

4 Goodyear, Irvine, CA 92618

Tel: (800) 722-2528, (949) 859-8999; Fax: (949) 859-7139

atsinfo@astronics.com atssales@astronics.com
atshelpdesk@astronics.com <http://www.astronictestsystems.com>

**THANK YOU FOR PURCHASING THIS
ASTRONICS TEST SYSTEMS PRODUCT**

For this product, or any other Astronics Test Systems product that incorporates software drivers, you may access our web site to verify and/or download the latest driver versions. The web address for driver downloads is:

<http://www.astronictestsystems.com/support/downloads>

If you have any questions about software driver downloads or our privacy policy, please contact us at:

atsinfo@astronics.com

WARRANTY STATEMENT

All Astronics Test Systems products are designed to exacting standards and manufactured in full compliance to our AS9100 Quality Management System processes.

This warranty does not apply to defects resulting from any modification(s) of any product or part without Astronics Test Systems express written consent, or misuse of any product or part. The warranty also does not apply to fuses, software, non-rechargeable batteries, damage from battery leakage, or problems arising from normal wear, such as mechanical relay life, or failure to follow instructions.

This warranty is in lieu of all other warranties, expressed or implied, including any implied warranty of merchantability or fitness for a particular use. The remedies provided herein are buyer's sole and exclusive remedies.

For the specific terms of your standard warranty, contact Customer Support. Please have the following information available to facilitate service.

1. Product serial number
2. Product model number
3. Your company and contact information

You may contact Customer Support by:

E-Mail:	atshelpdesk@astronics.com	
Telephone:	+1 800 722 3262	(USA)
Fax:	+1 949 859 7139	(USA)

RETURN OF PRODUCT

Authorization is required from Astronics Test Systems before you send us your product or sub-assembly for service or calibration. Call or contact Customer Support at 1-800-722-3262 or 1-949-859-8999 or via fax at 1-949-859-7139. We can also be reached at: atshelpdesk@astronics.com.

If the original packing material is unavailable, ship the product or sub-assembly in an ESD shielding bag and use appropriate packing materials to surround and protect the product.

PROPRIETARY NOTICE

This document and the technical data herein disclosed, are proprietary to Astronics Test Systems, and shall not, without express written permission of Astronics Test Systems, be used in whole or in part to solicit quotations from a competitive source or used for manufacture by anyone other than Astronics Test Systems. The information herein has been developed at private expense, and may only be used for operation and maintenance reference purposes or for purposes of engineering evaluation and incorporation into technical specifications and other documents which specify procurement of products from Astronics Test Systems.

TRADEMARKS AND SERVICE MARKS

All trademarks and service marks used in this document are the property of their respective owners.

- Racal Instruments, Talon Instruments, Trig-Tek, ActivATE, Adapt-A-Switch, N-GEN, and PAWS are trademarks of Astronics Test Systems in the United States.

DISCLAIMER

Buyer acknowledges and agrees that it is responsible for the operation of the goods purchased and should ensure that they are used properly and in accordance with this document and any other instructions provided by Seller. Astronics Test Systems products are not specifically designed, manufactured or intended to be used as parts, assemblies or components in planning, construction, maintenance or operation of a nuclear facility, or in life support or safety critical applications in which the failure of the Astronics Test Systems product could create a situation where personal injury or death could occur. Should Buyer purchase Astronics Test Systems product for such unintended application, Buyer shall indemnify and hold Astronics Test Systems, its officers, employees, subsidiaries, affiliates and distributors harmless against all claims arising out of a claim for personal injury or death associated with such unintended use.

FOR YOUR SAFETY

Before undertaking any troubleshooting, maintenance or exploratory procedure, read carefully the **WARNINGS** and **CAUTION** notices.



CAUTION
RISK OF ELECTRICAL SHOCK
DO NOT OPEN



This equipment contains voltage hazardous to human life and safety, and is capable of inflicting personal injury.



If this instrument is to be powered from the AC line (mains) through an autotransformer, ensure the common connector is connected to the neutral (earth pole) of the power supply.



Before operating the unit, ensure the conductor (green wire) is connected to the ground (earth) conductor of the power outlet. Do not use a two-conductor extension cord or a three-prong/two-prong adapter. This will defeat the protective feature of the third conductor in the power cord.



Maintenance and calibration procedures sometimes call for operation of the unit with power applied and protective covers removed. Read the procedures and heed warnings to avoid "live" circuit points.

Before operating this instrument:

1. Ensure the proper fuse is in place for the power source to operate.
2. Ensure all other devices connected to or in proximity to this instrument are properly grounded or connected to the protective third-wire earth ground.

If the instrument:

- fails to operate satisfactorily
- shows visible damage
- has been stored under unfavorable conditions
- has sustained stress

Do not operate until performance is checked by qualified personnel.

CE Declaration of Conformity

We

Astronics Test Systems
4 Goodyear
Irvine, CA 92618

declare under sole responsibility that the

1260-43, P/N 408006

conforms to the following Product Specifications:

EMC: EN61326:1998 +A1: 1998 +A2: 2001

FCC CFR 47, PART 18 SUBPART B **CLASS A**

ICES-003 ISSUE 4: February 2004 **CLASS A**

Supplementary Information:

The above specifications are met when the product is installed in an Astronics Test Systems certified mainframe with faceplates installed over all unused slots, as applicable

The product herewith complies with the requirements of the Low Voltage Directive 73/23/EEC and the EMC Directive 89/336/EEC (modified by 93/68/EEC).

Irvine, CA, May 20, 2006



VP of Engineering
Karen Evensen

This page was left intentionally blank.

Table of Contents

Chapter 1	1-1
SPECIFICATIONS	1-1
Introduction	1-1
Specifications	1-3
Ordering Information	1-5
Chapter 2	2-1
INSTALLATION INSTRUCTIONS.....	2-1
Unpacking and Inspection	2-1
Module Installation.....	2-1
Module Configuration	2-2
Front Panel Connectors	2-5
Mating Cables.....	2-10
More About Maximum Current Ratings	2-11
Installation	2-11

Chapter 3 3-1

MODULE OPERATION 3-1

 Operating Modes 3-1

 Operating The 1260-43 in Register-Based Mode 3-1

 Matrix Load Configuration 3-46

Appendix A A-1

LOGICAL RELAY LAYOUT A-1

Appendix B B-1

1260-43 RELAY LAYOUT B-1

List of Figures

Figure 1-1, The 1260-43 1-2

Figure 2-1, 1260-43, Physical Block Diagram 2-3

Figure 2-2, 1260-43, Logical Block Diagram 2-4

Figure 2-3, Front Panel Connector Numbering 2-5

Figure 3-1, Register-Based Mode of Operation..... 3-1

List of Tables

Table 2-1, 1260-43 Front Panel Pinouts 2-6

Table 2-2, Mating Cable Manufactures 2-10

Table 3-1, Control/ Status Register Address Offset Assignments..... 3-3

Table 3-2, Control/ Status Register Relay Assignments 3-10

Table 3-3, Matrix Load Selection 3-46

DOCUMENT CHANGE HISTORY

Revision	Date	Description of Change
A	11/16/09	Revised per EO 29965 Revised format to current standards. Company name revised throughout manual. Manual now revision letter controlled. Added Document Change History Page v. Back of cover sheet. Revised Warranty Statement, Return of Product, Proprietary Notice and Disclaimer to current standards. Removed Reshipment Instructions in (Chap. 2-1) and removed (Chap 4). Information. Now appears in first 2 sheets behind cover sheet. Updated table of contents to reflect changes made. . Added to footer: company name... to lower corner opposite of Page no's i thru vi.
B	9/24/13	Revised per ECN03606 to change Table J207.

This page was left intentionally blank.

Chapter 1

SPECIFICATIONS

Introduction

The 1260-43 is an ultra high-density matrix switch card. Each module consists of three 8x24 matrices, which are interconnected via a 10-lane buss. On-board configuration relays allow software control of the matrix configuration.

Multiple modules can be linked together via a front panel 10-lane buss to form larger matrices. This allows the user to construct very large Matrices.

With its combination of density, versatility, expandability, and excellent signal integrity, the 1260-43 is ideal for constructing large switching systems. It allows great flexibility in the connection of a large numbers of instruments to a large number of test points. The 1260-43 is an excellent choice for continuity, audio, video, telecom, datacom, and ATE systems testing.

An Option 01T is required to communicate with any set of switch cards. Provisions for an Option 01T is not provided for on the 1260-43. Another switch card must be in the system that has an Option 01T installed in order for the 1260-43 to work.

The following features are included in the 1260-43

- Data-Driven embedded descriptor, allowing immediate use with any Option-01T switch controller, regardless of firmware revision level.
- Three 8x24 Matrices in a Single VXI Slot
- 10 Lane Matrix expansion Buss
- Programmable Load Terminations
- Link Multiple modules via the front panel

Each switch can handle current up to 2 Amps. The 1260-43 plug-in fits into a standard VXI chassis.



Figure 1-1, The 1260-43

Specifications

Bandwidth (-3dB)	
8 x 24 cfg:	> 40 MHz
1 x 4 cfg:	> 40 MHz
Isolation	
8 x 24 cfg:	
100 KHz	> 80 dB
1 MHz	> 60 dB
10 MHz	
1 x 4 cfg:	
100 KHz	> 80 dB
1 MHz	> 60 dB
10 MHz	
Insertion Loss	
8 x 24 cfg:	
10 MHz	< 1 dB
40 MHz	< 3 dB
1 x 4 cfg:	
10 MHz	< 1 dB
40 MHz	< 2 dB
Crosstalk	
8 x 24 cfg:	
100 KHz	< -70 dB
1 MHz	< -55 dB
10 MHz	< -38 dB
1 x 4 cfg:	
100 KHz	< -70 dB
1 MHz	< -60 dB
10 MHz	< -40 dB
Switching Voltage	
AC	250 V, Max
DC	220 V, Max
Switching Current	
AC	2 A, Max.
DC	2 A, Max
Switching Power	60W, 62.5 VA, Max
Path resistance	
8 x 24 cfg:	< 900 m Ω @ 1A, < 1.1 Ω @ 1 mA
1 x 4 cfg:	< 500 m Ω @ 1A, < 600 m Ω @ 1 mA

Note: When using expansion buss in configuration, add an additional 500 m Ω

Module Capacitance	
8 x 24 cfg:	< 300 pF
1 x 4 cfg:	< 250 pF
<i>Note: When using expansion buss in configuration, add an additional 50 pF</i>	
Impedance	50 Ohms @ 5 MHz
Noise Floor (100Hz B/W, 0 to 10 MHz)	< -100dbm
Leakage to Ground	> 100 MΩ
Impulse Withstanding Voltage	> 100 Vrms
Insulation resistance	> 10 ⁹ Ω
Relay Settling Time	< 10 ms
Shock	30g, 11 ms, ½ sine wave
Vibration	0.013 in. P-P, 5-55 Hz
Bench Handling	4 in., 45°
Cooling	Airflow: 5.6 liters/sec Backpressure: 0.59 mm H2O
Temperature	
Operating	0°C to +55°C
Non-operating	-40°C to +75°C
Relative Humidity	85%, non-condensing at < 30°C
Altitude	
Operating	10,000 feet*
Non-operating	15,000 feet
Power Requirements (for 20 mA per energized relay)	8.5 A max. @ +5V
Weight	4.7 lbs
MTBF (including relays)	25,535 hours (MIL-HDBK-217E)
Relay Life Expectancy	
Mechanical	1X10 ⁸ operations
Electrical	500,000 operations at 30V / 1A
Dimensions (Module)	C-Size, Single Slot VXI buss Module

*Operation at 15,000 feet requires de-rating of maximum overall power dissipation to 49W.

Ordering Information

Listed below are part numbers for the 1260-43 switch module. The 1260-43 uses an IDC type of mating connector.

ITEM	DESCRIPTION	PART #
1260-43 Switch Module	1260-43, 3, 8 x 24, 1-wire, 2A, Multiplexer, 3 Bit Output Buss Shift	408006-001
Interconnecting Buss Cable	Cable, 1260-43, 20 Position, 4", Point to Point	602715-001
I/O Buss Cable	Cable, 1260-43, 20 Position, 3'	602715-002
I/O Buss Cable	Cable, 1260-43, 34 Position, 3'	602715-003
Additional Manual		980673-067
1260-43 Switch Module	1260-43, 3, 8 x 24, 1-wire, 2A Multiplexer, 1 Bit Output, Buss Shift	408006 Note*
Interconnecting Buss Cable	Cable, 1260-43, 20 Position, 4" with built-in 2 Bit Output Buss Shift	602780

*Note: The 602780 cable should be used when daisy-chaining two or more 408006's together in order to meet the IFTE specification.

This page was left intentionally blank.

Chapter 2

INSTALLATION INSTRUCTIONS

Unpacking and Inspection

1. Remove the 1260-43 module and inspect it for damage. If any damage is apparent, inform the carrier immediately. Retain shipping carton and packing material for the carrier's inspection.
2. Verify that the pieces in the package you received contain the correct 1260-43 module option and the 1260-43 Users Manual. Notify Customer Service if the module appears damaged in any way. Do not attempt to install a damaged module into a VXI chassis.
3. The 1260-43 module is shipped in an anti-static bag to prevent electrostatic damage to the module. Do not remove the module from the anti-static bag unless it is in a static-controlled area.

Module Installation

Installation of the 1260-43 Switching Module into a VXI mainframe, including the setting of switches SW1-1 through SW1-4, is described in the Setup Section of the 1260A Option 01T Users Manual, Publication No. 980806-999.

Module Configuration

The 1260-43 is an ultra high-density matrix switch card. Each module consists of three 8x24, single wire matrices, which are interconnected via a 10-lane buss. On-board configuration relays allow software control of the matrix configuration.

The 1260-43 is comprised of three boards, the 405237, 405249 and the 405250. The main controller board (405249) interfaces to the VXI buss and thus has all the control logic for communicating with the buss. In addition the control board decodes the address's that select the relay read/write ports. The relay board (405237) contains 900 relays of which 450 relays are on top with another 450 relays on the bottom. The control board connects to the relay board via five 200 pin connectors. The connectors pass the relay coil enabling signals from the control board to the relay board. The interface board (405250) contains 8 connectors used to connect to the outside world. The interface board connects to the relay board using two 80-pin flex cables.

The interface board shifts the 'Output Buss' three positions to the right before connecting to J207. This is transparent to the user and is done so the 1260-43 is compliant with the IFTE specification when daisy-chaining two or more 1260-43's together. This shift eliminates the need to place the shift in the daisy-chaining cable. Thus the daisy-chaining cable becomes point-to-point.

If a 408006 (1260-43) is used, a 602780 cable is required in order to meet the IFTE specification.

For a block diagram of the 1260-43, refer to both **Figure 2-1** and **Figure 2-2**.

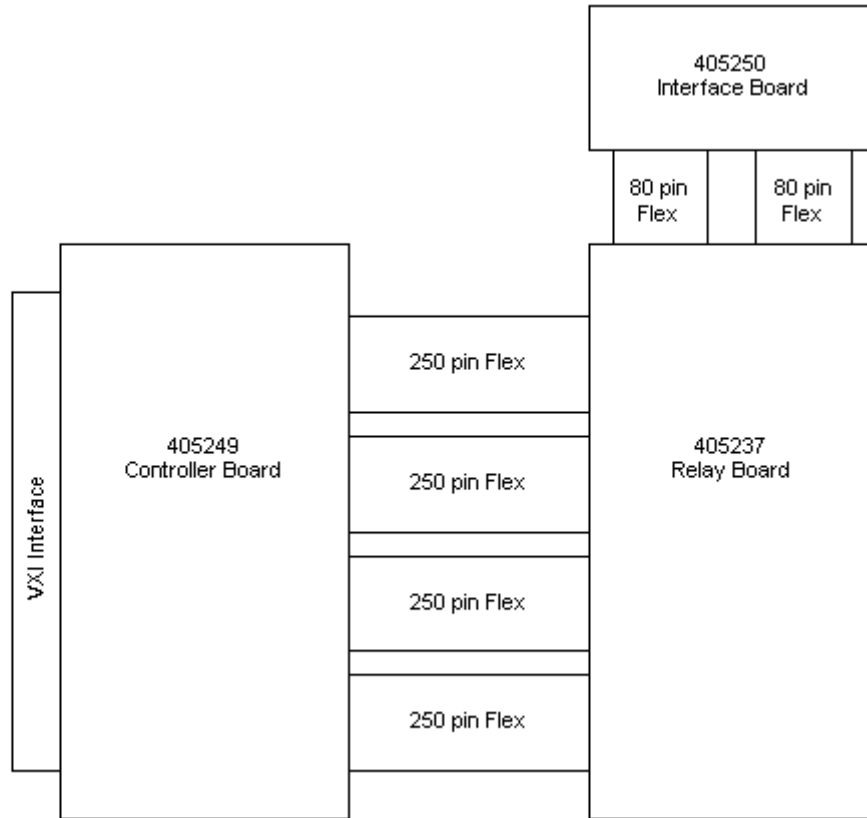

Figure 2-1, 1260-43, Physical Block Diagram

1260-43 Block Diagram

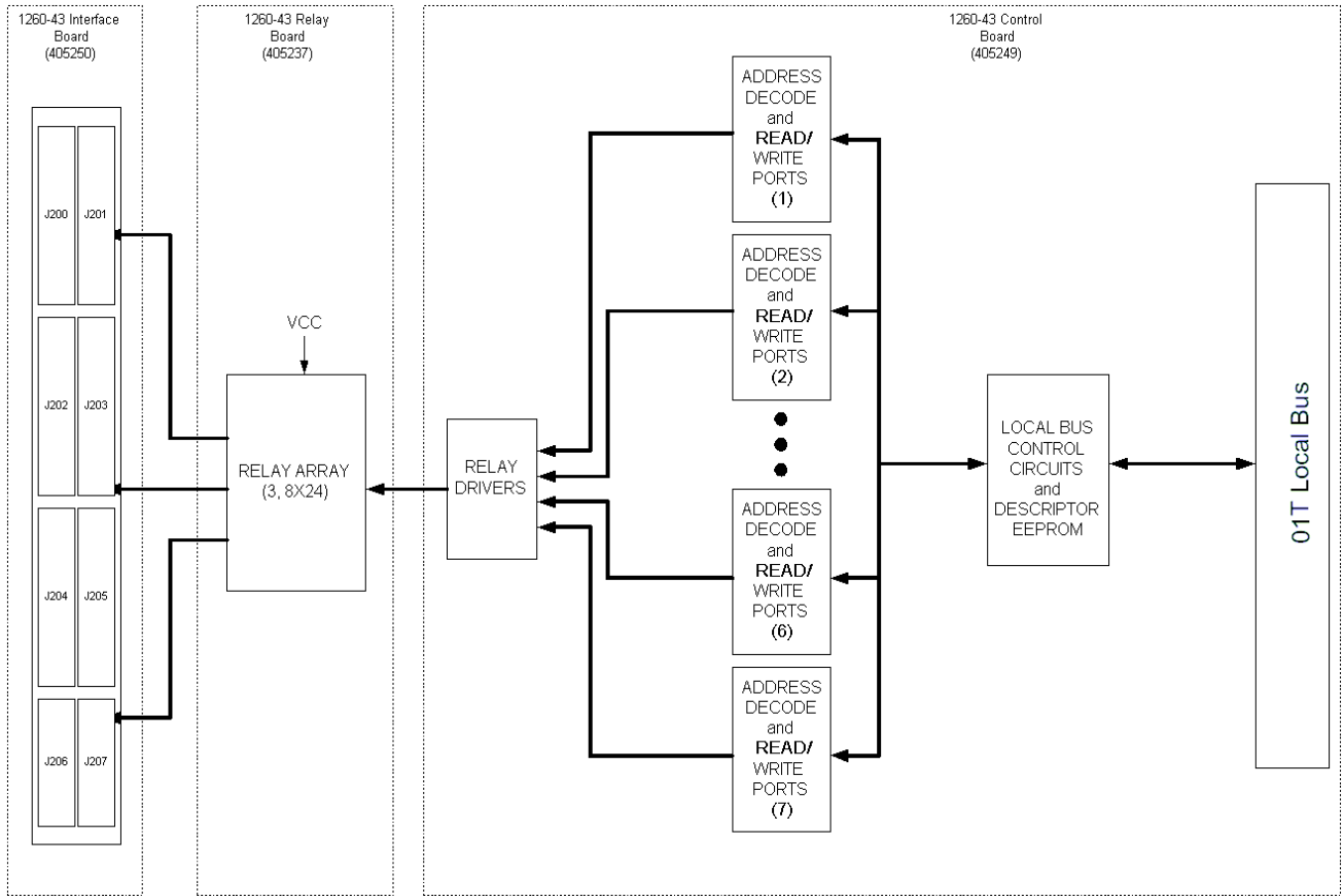

Figure 2-2, 1260-43, Logical Block Diagram

Front Panel Connectors

The 1260-43 has six 34-pin front-panel connectors, labeled J200-J205 and two 20-pin connectors, labeled J206 and J207. Each matrix consists of a pair of 34-pin connectors. The two 20-pin connectors are used for bussing the 10-lane buss in and out of the 1260-43. The output of the 10-lane buss that connects to J207 incorporates a 3-bit shift to the right. This allows compliancy to the IFTE specification when daisy-chaining two or more 1260-43's in a system and eliminates the need for a special cable. If a 408006 (1260-43) is used, a 602780 cable is required in order to meet the IFTE specification. See **Figure 2-3** for front panel connector locations. **Table 2-1** shows the signal assignments to connector pins.

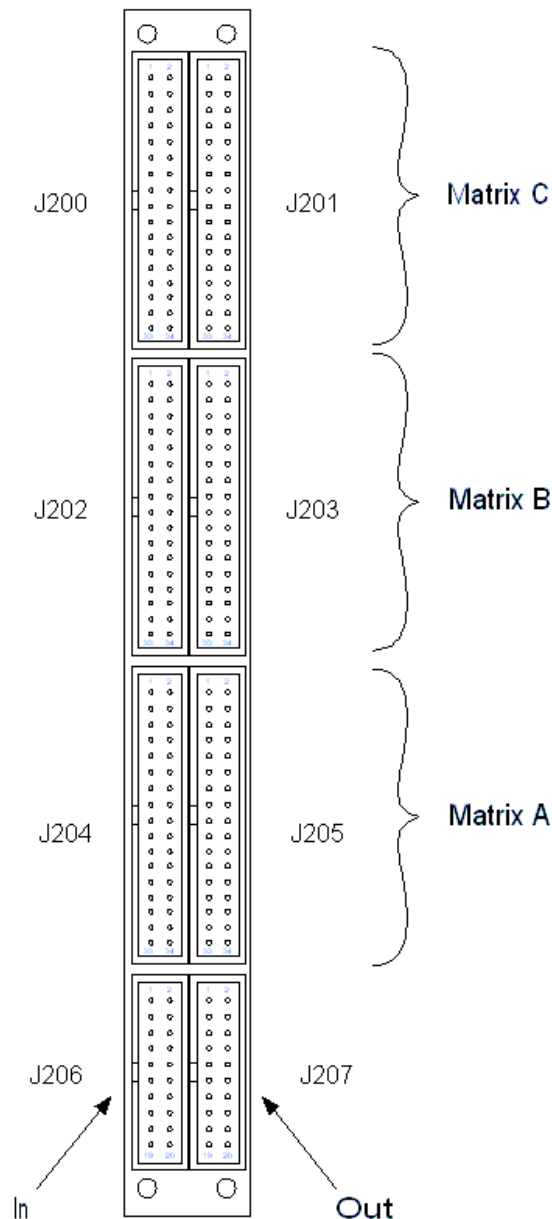

Figure 2-3, Front Panel Connector Numbering

Table 2-1, 1260-43 Front Panel Pinouts

J200			
1	GND	2	O23C+
3	GND	4	O21C+
5	GND	6	O19C+
7	GND	8	O17C+
9	GND	10	O15C+
11	GND	12	O13C+
13	GND	14	O11C+
15	GND	16	O9C+
17	GND	18	O7C+
19	GND	20	O5C+
21	GND	22	O3C+
23	GND	24	O1C+
25	GND	26	I7C+
27	GND	28	I5C+
29	GND	30	I3C+
31	GND	32	I1C+
33	NC	34	NC

J201			
1	GND	2	O24C+
3	GND	4	O22C+
5	GND	6	O20C+
7	GND	8	O18C+
9	GND	10	O16C+
11	GND	12	O14C+
13	GND	14	O12C+
15	GND	16	O10C+
17	GND	18	O8C+
19	GND	20	O6C+
21	GND	22	O4C+
23	GND	24	O2C+
25	GND	26	I8C+
27	GND	28	I6C+
29	GND	30	I4C+
31	GND	32	I2C+
33	NC	34	NC

J202			
1	GND	2	O23B+
3	GND	4	O21B+
5	GND	6	O19B+
7	GND	8	O17B+
9	GND	10	O15B+
11	GND	12	O13B+
13	GND	14	O11B+
15	GND	16	O9B+
17	GND	18	O7B+
19	GND	20	O5B+
21	GND	22	O3B+
23	GND	24	O1B+
25	GND	26	I7B+
27	GND	28	I5B+
29	GND	30	I3B+
31	GND	32	I1B+
33	NC	34	NC

J203			
1	GND	2	O24B+
3	GND	4	O22B+
5	GND	6	O20B+
7	GND	8	O18B+
9	GND	10	O16B+
11	GND	12	O14B+
13	GND	14	O12B+
15	GND	16	O10B+
17	GND	18	O8B+
19	GND	20	O6B+
21	GND	22	O4B+
23	GND	24	O2B+
25	GND	26	I8B+
27	GND	28	I6B+
29	GND	30	I4B+
31	GND	32	I2B+
33	NC	34	NC

J204			
1	GND	2	O23A+
3	GND	4	O21A+
5	GND	6	O19A+
7	GND	8	O17A+
9	GND	10	O15A+
11	GND	12	O13A+
13	GND	14	O11A+
15	GND	16	O9A+
17	GND	18	O7A+
19	GND	20	O5A+
21	GND	22	O3A+
23	GND	24	O1A+
25	GND	26	I7A+
27	GND	28	I5A+
29	GND	30	I3A+
31	GND	32	I1A+
33	NC	34	NC

J205			
1	GND	2	O24A+
3	GND	4	O22A+
5	GND	6	O20A+
7	GND	8	O18A+
9	GND	10	O16A+
11	GND	12	O14A+
13	GND	14	O12A+
15	GND	16	O10A+
17	GND	18	O8A+
19	GND	20	O6A+
21	GND	22	O4A+
23	GND	24	O2A+
25	GND	26	I8A+
27	GND	28	I6A+
29	GND	30	I4A+
31	GND	32	I2A+
33	NC	34	NC

J206			
1	GND	2	BUS_IN 9+
3	GND	4	BUS_IN 8+
5	GND	6	BUS_IN 7+
7	GND	8	BUS_IN 6+
9	GND	10	BUS_IN 5+
11	GND	12	BUS_IN 4+
13	GND	14	BUS_IN 3+
15	GND	16	BUS_IN 2+
17	GND	18	BUS_IN 1+
19	GND	20	BUS_IN 0+

J207				
1	GND	2	BUS_OUT 0+	Buss Signal 2
3	GND	4	BUS_OUT 9+	Buss Signal 1
5	GND	6	BUS_OUT 8+	Buss Signal 0
7	GND	8	BUS_OUT 7+	Buss Signal 9
9	GND	10	BUS_OUT 6+	Buss Signal 8
11	GND	12	BUS_OUT 5+	Buss Signal 7
13	GND	14	BUS_OUT 4+	Buss Signal 6
15	GND	16	BUS_OUT 3+	Buss Signal 5
17	GND	18	BUS_OUT 2+	Buss Signal 4
19	GND	20	BUS_OUT 1+	Buss Signal 3

Mating Cables

The front panel connectors are a standard IDC type of connector. The mating connectors are unique due to the coax cabling. Special manufacturing processes are required in joining the coax cable to the mating connector. This prohibits manufactures from selling Individual connector parts. Only finished cable assemblies are sold. Mating cable/connector assemblies are available from Joy Signal, Molex and 3M.

Table 2-2 contains manufacture's part numbers for the cable/connector assemblies used by the 1260-43.

Table 2-2, Mating Cable Manufactures

Manufacturer	20 Pin Mating Cable	34 Pin Mating Cable
Joy Signal	SSC-02-02-3-20-09-XXX.00	ZZC-02-02-03-34-01-XXX.00
Molex	ZZC-02-02-03-20-01-XXX.00	SSC-02-02-3-34-09-XXX.00

Note: *XXX equals the cable length in inches.*

More About Maximum Current Ratings

The front panel connector and pins are rated for 2 A per pin, with all channels conducting full-rated current. The relays are rated at 2 A. This keeps the temperature rise within 10°C.

Definitions:

- *Max current carrying capacity*

The maximum current that the relay can conduct if the relay is not switched while voltage is applied. The maximum current carrying capacity is affected by the size of the conducting section of the contact at its smallest area. The listed values are obtained from several tests in laboratories under room-temperature conditions (21°C). The contact is considered to be in free air. The maximum current carrying for the 1260-43 is 2.5 A.

- *Max operating current*

The current the contacts can switch while conducting, without deteriorating. This depends on working conditions, such as dissipated heat, cooling provisions, ambient temperature, insulation material, etc. The maximum operating current for the 1260-43 is 2 A.

- *Recommended continuous current*

The maximum current recommended for indefinitely-long time periods. The primary concern here is the heat generated in the relay. This specification can be applied for normal working conditions. The specification includes a safety margin. However, there are restrictions in the application of the given values. The most important restriction is the cross-sectional area of the connecting wire, insulation temperature range, and wire bundling. The recommended continuous current for the 1260-43 is 2 A.

Installation

To install the 1260-43 Switching Module into a VXI mainframe chassis, engage the printed circuit board into the grooves of the desired chassis slot. Slide the 1260-43 into the chassis until its connector mates with the connector on the chassis backplane. Push firmly to fully seat the connector. Tighten the two retaining screws at the top and bottom of the 1260-43 plug-in.

A 01T is required in the system in order for the 1260-43 to operate. An additional VXI Switch card containing a 01T needs to be installed in the system with the slot location to the left of the 1260-43.

This page was left intentionally blank.

Chapter 3

MODULE OPERATION

Operating Modes

The 1260-43 is operated in *register-based* mode.

In the *register-based* mode, the user writes directly to the control registers on the 1260-43 module. The 1260-01T command module does not monitor these operations, and does not keep track of the relay states on the 1260-43 module in this mode.

A conceptual view of the register-based mode is shown in **Figure 3-1** below.

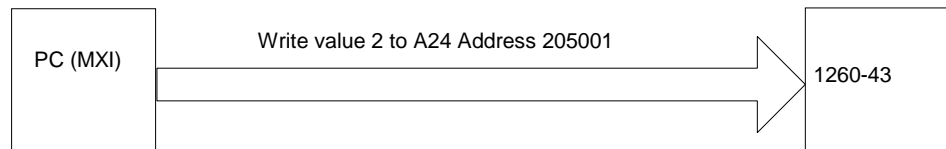

Figure 3-1, Register-Based Mode of Operation

The register-based mode provides faster control of relay channels. In this mode, relay operations are processed in less than 9 microseconds, not counting relay settling time or software overhead inherent in I/O libraries such as VISA. To determine the relay settling time, refer to Relay Settling Time in the Specifications section.

Operating The 1260-43 in Register-Based Mode

In register-based mode, the 1260-43 is operated by directly writing to control registers and reading from status registers on the 1260-43 module. There are 180 control/status register pairs on the 1260-43 module. When a control register is written to, all channels controlled by that register are operated simultaneously. Default value for all control registers is hex '00' after reset.

The 1260-43 has a 10-Lane buss that is routed through the three

matrices (refer to Appendix A.) With the exception of the matrix output relay groups, each group of relays operating on the buss is comprised of 10 relays. The matrix output relay groups only operate on 5 of the 10 signals of the buss and thus have only one control/status register associated with each group. For the rest of the relay groups an A and B control/status register pair is assigned to each group. Only bits 4-0 of the register are used. Bits 7-5 are not used and will display "111" when the status register is read. Register 'A' is assigned to buss signals 4-0 while register 'B' is assigned to buss signals 9-5.

The control registers are located in the VXI buss A24 Address Space. The A24 address for a control register depends on:

1. The A24 Address Offset assigned to the 1260-01T module by the Resource Manager program. The Resource Manager program is provided by the VXI buss slot-0 controller vendor. The A24 Address Offset is placed into the "Offset Register" of the 1260-01T by the Resource Manager.
2. The <module address> of the 1260-43 module. This is a value in the range 1 through 12.
3. Each control / status register on the 1260-43 has a unique address.

The base A24 address for the 1260-43 module may be calculated by:

$$(A24 \text{ Offset of Option-01T}) + (1024 \times \text{Module Address of } 1260-43).$$

The A24 address offset is usually expressed in hexadecimal. A typical value of 204000_{16} is used in the examples that follow.

A 1260-43 with a module address of 6 would have the base A24 address computed as follows:

$$\begin{aligned} \text{Base A24 Address of } 1260-43 &= 204000_{16} + (400_{16} \times 6_{10}) \\ &= 205800_{16} \end{aligned}$$

The control registers for 1260-Series VXI modules are always on odd-numbered A24 addresses. The first two control registers for the 1260-43 reside at the first two odd-numbered A24 addresses for the module:

$$(\text{Base A24 Address of } 1260-43) + 1 = \text{Control Reg. } 0$$

$$(\text{Base A24 Address of } 1260-43) + 3 = \text{Control Reg. } 1$$

So, for our example, the two control registers are located at:

205801 Control Register 0

205803 Control Register 1

Table 3-1 shows the address offset assignments for each Control/Status register while **Table 3-2** shows the Control/Status Register Relay / Buss Assignments. Refer to **Appendix A** and **B** in determining relay groups and the relay reference designations.

Table 3-1, Control/ Status Register Address Offset Assignments

Control/Status	Address	Function
Reg. 00A	001	Input Bus to Matrix Bus 'A' (lower bus bits 4-0)
Reg. 00B	003	Input Bus to Matrix Bus 'A' (upper bus bits 9-5)
Reg. 01A	005	Bypass Matrix Bus 'A' to Internal Bus 'B' (lower bus bits 4-0)
Reg. 01B	007	Bypass Matrix Bus 'A' to Internal Bus 'B' (upper bus bits 9-5)
Reg. 02A	009	Internal Bus 'B' to Matrix Bus 'B' (lower bus bits 4-0)
Reg. 02B	00B	Internal Bus 'B' to Matrix Bus 'B' (upper bus bits 9-5)
Reg. 03A	00D	Bypass Matrix Bus 'B' to Internal Bus 'C' (lower bus bits 4-0)
Reg. 03B	00F	Bypass Matrix Bus 'B' to Internal Bus 'C' (upper bus bits 9-5)
Reg. 04A	011	Internal Bus 'C' to Matrix Bus 'C' (lower bus bits 4-0)
Reg. 04B	013	Internal Bus 'C' to Matrix Bus 'C' (upper bus bits 9-5)
Reg. 05A	015	Bypass Matrix Bus 'C' to Output Bus (lower bus bits 4-0)
Reg. 05B	017	Bypass Matrix Bus 'C' to Output Bus (upper bus bits 9-5)
Reg. 06A	019	Matrix Bus 'A' Stub Break 1 (lower bus bits 4-0)
Reg. 06B	01B	Matrix Bus 'A' Stub Break 1 (upper bus bits 9-5)
Reg. 07A	01D	Matrix Bus 'A' Stub Break 2 (lower bus bits 4-0)
Reg. 07B	01F	Matrix Bus 'A' Stub Break 2 (upper bus bits 9-5)
Reg. 08A	021	Matrix Bus 'A' Stub Break 3 (lower bus bits 4-0)
Reg. 08B	023	Matrix Bus 'A' Stub Break 3 (upper bus bits 9-5)
Reg. 09A	025	Matrix Bus 'A' Stub Break 4 (lower bus bits 4-0)
Reg. 09B	027	Matrix Bus 'A' Stub Break 4 (upper bus bits 9-5)
Reg. 10A	029	Matrix Bus 'B' Stub Break 1 (lower bus bits 4-0)

Reg. 10B	02B	Matrix Bus 'B' Stub Break 1 (upper bus bits 9-5)
Reg. 11A	02D	Matrix Bus 'B' Stub Break 2 (lower bus bits 4-0)
Reg. 11B	02F	Matrix Bus 'B' Stub Break 2 (upper bus bits 9-5)
Reg. 12A	031	Matrix Bus 'B' Stub Break 3 (lower bus bits 4-0)
Reg. 12B	033	Matrix Bus 'B' Stub Break 3 (upper bus bits 9-5)
Reserved	035-03F	
Reg. 13A	041	Matrix Bus 'B' Stub Break 4 (lower bus bits 4-0)
Reg. 13B	043	Matrix Bus 'B' Stub Break 4 (upper bus bits 9-5)
Reg. 14A	045	Matrix Bus 'C' Stub Break 1 (lower bus bits 4-0)
Reg. 14B	047	Matrix Bus 'C' Stub Break 1 (upper bus bits 9-5)
Reg. 15A	049	Matrix Bus 'C' Stub Break 2 (lower bus bits 4-0)
Reg. 15B	04B	Matrix Bus 'C' Stub Break 2 (upper bus bits 9-5)
Reg. 16A	04D	Matrix Bus 'C' Stub Break 3 (lower bus bits 4-0)
Reg. 16B	04F	Matrix Bus 'C' Stub Break 3 (upper bus bits 9-5)
Reg. 17A	051	Matrix Bus 'C' Stub Break 4 (lower bus bits 4-0)
Reg. 17B	053	Matrix Bus 'C' Stub Break 4 (upper bus bits 9-5)
Reg. 18A	055	Matrix Bus 'A' Pull-up/Pull-down for Load 1
Reg. 18B	057	Matrix Bus 'A' Pull-up/Pull-down for Load 2
Reg. 19A	059	Matrix Bus 'A' Resistor Selection for Load 1
Reg. 19B	05B	Matrix Bus 'A' Resistor Selection for Load 2
Reg. 20A	05D	Matrix Bus 'A' Load 1 Connection (lower bus bits 4-0)
Reg. 20B	05F	Matrix Bus 'A' Load 1 Connection (upper bus bits 9-5)
Reg. 21A	061	Matrix Bus 'A' Load 2 Connection (lower bus bits 4-0)
Reg. 21B	063	Matrix Bus 'A' Load 2 Connection (upper bus bits 9-5)
Reg. 22A	065	Matrix Bus 'B' Pull-up/Pull-down for Load 1
Reg. 22B	067	Matrix Bus 'B' Pull-up/Pull-down for Load 2
Reg. 23A	069	Matrix Bus 'B' Resistor Selection for Load 1
Reg. 23B	06B	Matrix Bus 'B' Resistor Selection for Load 2
Reg. 24A	06D	Matrix Bus 'B' Load 1 Connection (lower bus bits 4-0)
Reg. 24B	06F	Matrix Bus 'B' Load 1 Connection (upper bus bits 9-5)

Reg. 25A	071	Matrix Bus 'B' Load 2 Connection (lower bus bits 4-0)
Reg. 25B	073	Matrix Bus 'B' Load 2 Connection (upper bus bits 9-5)
Reserved	075-07F	
Reg. 26A	081	Matrix Bus 'C' Pull-up/Pull-down for Load 1
Reg. 26B	083	Matrix Bus 'C' Pull-up/Pull-down for Load 2
Reg. 27A	085	Matrix Bus 'C' Resistor Selection for Load 1
Reg. 27B	087	Matrix Bus 'C' Resistor Selection for Load 2
Reg. 28A	089	Matrix Bus 'C' Load 1 Connection (lower bus bits 4-0)
Reg. 28B	08B	Matrix Bus 'C' Load 1 Connection (upper bus bits 9-5)
Reg. 29A	08D	Matrix Bus 'C' Load 2 Connection (lower bus bits 4-0)
Reg. 29B	08F	Matrix Bus 'C' Load 2 Connection (upper bus bits 9-5)
Reg. 30A	091	Matrix Bus 'A' Instrument Input 1 (lower bus bits 4-0)
Reg. 30B	093	Matrix Bus 'A' Instrument Input 1 (upper bus bits 9-5)
Reg. 31A	095	Matrix Bus 'A' Instrument Input 2 (lower bus bits 4-0)
Reg. 31B	097	Matrix Bus 'A' Instrument Input 2 (upper bus bits 9-5)
Reg. 32A	099	Matrix Bus 'A' Instrument Input 3 (lower bus bits 4-0)
Reg. 32B	09B	Matrix Bus 'A' Instrument Input 3 (upper bus bits 9-5)
Reg. 33A	09D	Matrix Bus 'A' Instrument Input 4 (lower bus bits 4-0)
Reg. 33B	09F	Matrix Bus 'A' Instrument Input 4 (upper bus bits 9-5)
Reg. 34A	0A1	Matrix Bus 'A' Instrument Input 5 (lower bus bits 4-0)
Reg. 34B	0A3	Matrix Bus 'A' Instrument Input 5 (upper bus bits 9-5)
Reg. 35A	0A5	Matrix Bus 'A' Instrument Input 6 (lower bus bits 4-0)
Reg. 35B	0A7	Matrix Bus 'A' Instrument Input 6 (upper bus bits 9-5)
Reg. 36A	0A9	Matrix Bus 'A' Instrument Input 7 (lower bus bits 4-0)
Reg. 36B	0AB	Matrix Bus 'A' Instrument Input 7 (upper bus bits 9-5)
Reg. 37A	0AD	Matrix Bus 'A' Instrument Input 8 (lower bus bits 4-0)
Reg. 37B	0AF	Matrix Bus 'A' Instrument Input 8 (upper bus bits 9-5)
Reg. 38	0B1	Matrix Bus 'A' Output 1
Reg. 39	0B3	Matrix Bus 'A' Output 2
Reserved	0B5-0BF	

Reg. 40	0C1	Matrix Bus 'A' Output 3
Reg. 41	0C3	Matrix Bus 'A' Output 4
Reg. 42	0C5	Matrix Bus 'A' Output 5
Reg. 43	0C7	Matrix Bus 'A' Output 6
Reg. 44	0C9	Matrix Bus 'A' Output 7
Reg. 45	0CB	Matrix Bus 'A' Output 8
Reg. 46	0CD	Matrix Bus 'A' Output 9
Reg. 47	0CF	Matrix Bus 'A' Output 10
Reg. 48	0D1	Matrix Bus 'A' Output 11
Reg. 49	0D3	Matrix Bus 'A' Output 12
Reg. 50	0D5	Matrix Bus 'A' Output 13
Reg. 51	0D7	Matrix Bus 'A' Output 14
Reg. 52	0D9	Matrix Bus 'A' Output 15
Reg. 53	0DB	Matrix Bus 'A' Output 16
Reg. 54	0DD	Matrix Bus 'A' Output 17
Reg. 55	0DF	Matrix Bus 'A' Output 18
Reg. 56	0E1	Matrix Bus 'A' Output 19
Reg. 57	0E3	Matrix Bus 'A' Output 20
Reg. 58	0E5	Matrix Bus 'A' Output 21
Reg. 59	0E7	Matrix Bus 'A' Output 22
Reg. 60	0E9	Matrix Bus 'A' Output 23
Reg. 61	0EB	Matrix Bus 'A' Output 24
Reg. 62A	0ED	Matrix Bus 'B' Instrument Input 1 (lower bus bits 4-0)
Reg. 62B	0EF	Matrix Bus 'B' Instrument Input 1 (upper bus bits 9-5)
Reg. 63A	0F1	Matrix Bus 'B' Instrument Input 2 (lower bus bits 4-0)
Reg. 63B	0F3	Matrix Bus 'B' Instrument Input 2 (upper bus bits 9-5)
Reserved	0F5-0FF	
Reg. 64A	101	Matrix Bus 'B' Instrument Input 3 (lower bus bits 4-0)
Reg. 64B	103	Matrix Bus 'B' Instrument Input 3 (upper bus bits 9-5)
Reg. 65A	105	Matrix Bus 'B' Instrument Input 4 (lower bus bits 4-0)

Reg. 65B	107	Matrix Bus 'B' Instrument Input 4 (upper bus bits 9-5)
Reg. 66A	109	Matrix Bus 'B' Instrument Input 5 (lower bus bits 4-0)
Reg. 66B	10B	Matrix Bus 'B' Instrument Input 5 (upper bus bits 9-5)
Reg. 67A	10D	Matrix Bus 'B' Instrument Input 6 (lower bus bits 4-0)
Reg. 67B	10F	Matrix Bus 'B' Instrument Input 6 (upper bus bits 9-5)
Reg. 68A	111	Matrix Bus 'B' Instrument Input 7 (lower bus bits 4-0)
Reg. 68B	113	Matrix Bus 'B' Instrument Input 7 (upper bus bits 9-5)
Reg. 69A	115	Matrix Bus 'B' Instrument Input 8 (lower bus bits 4-0)
Reg. 69B	117	Matrix Bus 'B' Instrument Input 8 (upper bus bits 9-5)
Reg. 70	119	Matrix Bus 'B' Output 1
Reg. 71	11B	Matrix Bus 'B' Output 2
Reg. 72	11D	Matrix Bus 'B' Output 3
Reg. 73	11F	Matrix Bus 'B' Output 4
Reg. 74	121	Matrix Bus 'B' Output 5
Reg. 75	123	Matrix Bus 'B' Output 6
Reg. 76	125	Matrix Bus 'B' Output 7
Reg. 77	127	Matrix Bus 'B' Output 8
Reg. 78	129	Matrix Bus 'B' Output 9
Reg. 79	12B	Matrix Bus 'B' Output 10
Reg. 80	12D	Matrix Bus 'B' Output 11
Reg. 81	12F	Matrix Bus 'B' Output 12
Reg. 82	131	Matrix Bus 'B' Output 13
Reg. 83	133	Matrix Bus 'B' Output 14
Reserved	135-13F	
Reg. 84	141	Matrix Bus 'B' Output 15
Reg. 85	143	Matrix Bus 'B' Output 16
Reg. 86	145	Matrix Bus 'B' Output 17
Reg. 87	147	Matrix Bus 'B' Output 18
Reg. 88	149	Matrix Bus 'B' Output 19
Reg. 89	14B	Matrix Bus 'B' Output 20

Reg. 90	14D	Matrix Bus 'B' Output 21
Reg. 91	14F	Matrix Bus 'B' Output 22
Reg. 92	151	Matrix Bus 'B' Output 23
Reg. 93	153	Matrix Bus 'B' Output 24
Reg. 94A	155	Matrix Bus 'C' Instrument Input 1 (lower bus bits 4-0)
Reg. 94B	157	Matrix Bus 'C' Instrument Input 1 (upper bus bits 9-5)
Reg. 95A	159	Matrix Bus 'C' Instrument Input 2 (lower bus bits 4-0)
Reg. 95B	15B	Matrix Bus 'C' Instrument Input 2 (upper bus bits 9-5)
Reg. 96A	15D	Matrix Bus 'C' Instrument Input 3 (lower bus bits 4-0)
Reg. 96B	15F	Matrix Bus 'C' Instrument Input 3 (upper bus bits 9-5)
Reg. 97A	161	Matrix Bus 'C' Instrument Input 4 (lower bus bits 4-0)
Reg. 97B	163	Matrix Bus 'C' Instrument Input 4 (upper bus bits 9-5)
Reg. 98A	165	Matrix Bus 'C' Instrument Input 5 (lower bus bits 4-0)
Reg. 98B	167	Matrix Bus 'C' Instrument Input 5 (upper bus bits 9-5)
Reg. 99A	169	Matrix Bus 'C' Instrument Input 6 (lower bus bits 4-0)
Reg. 99B	16B	Matrix Bus 'C' Instrument Input 6 (upper bus bits 9-5)
Reg. 100A	16D	Matrix Bus 'C' Instrument Input 7 (lower bus bits 4-0)
Reg. 100B	16F	Matrix Bus 'C' Instrument Input 7 (upper bus bits 9-5)
Reg. 101A	171	Matrix Bus 'C' Instrument Input 8 (lower bus bits 4-0)
Reg. 101B	173	Matrix Bus 'C' Instrument Input 8 (upper bus bits 9-5)
Reserved	175-17F	
Reg. 102	181	Matrix Bus 'C' Output 1
Reg. 103	183	Matrix Bus 'C' Output 2
Reg. 104	185	Matrix Bus 'C' Output 3
Reg. 105	187	Matrix Bus 'C' Output 4
Reg. 106	189	Matrix Bus 'C' Output 5
Reg. 107	18B	Matrix Bus 'C' Output 6
Reg. 108	18D	Matrix Bus 'C' Output 7
Reg. 109	18F	Matrix Bus 'C' Output 8
Reg. 110	191	Matrix Bus 'C' Output 9

Reg. 111	193	Matrix Bus 'C' Output 10
Reg. 112	195	Matrix Bus 'C' Output 11
Reg. 113	197	Matrix Bus 'C' Output 12
Reg. 114	199	Matrix Bus 'C' Output 13
Reg. 115	19B	Matrix Bus 'C' Output 14
Reg. 116	19D	Matrix Bus 'C' Output 15
Reg. 117	19F	Matrix Bus 'C' Output 16
Reg. 118	1A1	Matrix Bus 'C' Output 17
Reg. 119	1A3	Matrix Bus 'C' Output 18
Reg. 120	1A5	Matrix Bus 'C' Output 19
Reg. 121	1A7	Matrix Bus 'C' Output 20
Reg. 122	1A9	Matrix Bus 'C' Output 21
Reg. 123	1AB	Matrix Bus 'C' Output 22
Reg. 124	1AD	Matrix Bus 'C' Output 23
Reg. 125	1AF	Matrix Bus 'C' Output 24
ID Byte	201	Identification Byte (Read Only)
EPROM	203	EPROM Data (Read Only)

Table 3-2, Control/ Status Register Relay Assignments

Control/ Status Register	Input Bus to Matrix Bus 'A' (lower bus bits 4-0)							
	Bit 7 (MSB)	Bit 6	Bit 5	Bit 4	Bit 3	Bit 2	Bit 1	Bit 0 (LSB)
Reg. 00A	NC	NC	NC	K5	K4	K3	K2	K1
				Bus 4	Bus 3	Bus 2	Bus 1	Bus 0

Control/ Status Register	Input Bus to Matrix Bus 'A' (upper bus bits 9-5)							
	Bit 7 (MSB)	Bit 6	Bit 5	Bit 4	Bit 3	Bit 2	Bit 1	Bit 0 (LSB)
Reg. 00B	NC	NC	NC	K15	K14	K13	K12	K11
				Bus 9	Bus 8	Bus 7	Bus 6	Bus 5

Control/ Status Register	Bypass Matrix Bus 'A' to Internal Bus 'B' (lower bus bits 4-0)							
	Bit 7 (MSB)	Bit 6	Bit 5	Bit 4	Bit 3	Bit 2	Bit 1	Bit 0 (LSB)
Reg. 01A	NC	NC	NC	K10	K9	K8	K7	K6
				Bus 4	Bus 3	Bus 2	Bus 1	Bus 0

Control/ Status Register	Bypass Matrix Bus 'A' to Internal Bus 'B' (upper bus bits 9-5)							
	Bit 7 (MSB)	Bit 6	Bit 5	Bit 4	Bit 3	Bit 2	Bit 1	Bit 0 (LSB)
Reg. 01B	NC	NC	NC	K20	K19	K18	K17	K16
				Bus 9	Bus 8	Bus 7	Bus 6	Bus 5

Control/ Status Register	Internal Bus 'B' to Matrix Bus 'B' (lower bus bits 4-0)							
	Bit 7 (MSB)	Bit 6	Bit 5	Bit 4	Bit 3	Bit 2	Bit 1	Bit 0 (LSB)
Reg. 02A	NC	NC	NC	K25	K24	K23	K22	K21
				Bus 4	Bus 3	Bus 2	Bus 1	Bus 0

Control/ Status Register	Internal Bus 'B' to Matrix Bus 'B' (upper bus bits 9-5)							
	Bit 7 (MSB)	Bit 6	Bit 5	Bit 4	Bit 3	Bit 2	Bit 1	Bit 0 (LSB)
Reg. 02B	NC	NC	NC	K35	K34	K33	K32	K31
				Bus 9	Bus 8	Bus 7	Bus 6	Bus 5

Control/ Status Register	Bypass Matrix Bus 'B' to Internal Bus 'C' (lower bus bits 4-0)							
	Bit 7 (MSB)	Bit 6	Bit 5	Bit 4	Bit 3	Bit 2	Bit 1	Bit 0 (LSB)
Reg. 03A	NC	NC	NC	K30	K29	K28	K27	K26
				Bus 4	Bus 3	Bus 2	Bus 1	Bus 0

Control/ Status Register	Bypass Matrix Bus 'B' to Internal Bus 'C' (upper bus bits 9-5)							
	Bit 7 (MSB)	Bit 6	Bit 5	Bit 4	Bit 3	Bit 2	Bit 1	Bit 0 (LSB)
Reg. 03B	NC	NC	NC	K40	K39	K38	K37	K36
				Bus 9	Bus 8	Bus 7	Bus 6	Bus 5

Control/ Status Register	Internal Bus 'C' to Matrix Bus 'C' (lower bus bits 4-0)							
	Bit 7 (MSB)	Bit 6	Bit 5	Bit 4	Bit 3	Bit 2	Bit 1	Bit 0 (LSB)
Reg. 04A	NC	NC	NC	K45	K44	K43	K42	K41
				Bus 4	Bus 3	Bus 2	Bus 1	Bus 0

Control/ Status Register	Internal Bus 'C' to Matrix Bus 'C' (upper bus bits 9-5)							
	Bit 7 (MSB)	Bit 6	Bit 5	Bit 4	Bit 3	Bit 2	Bit 1	Bit 0 (LSB)
Reg. 04B	NC	NC	NC	K55	K54	K53	K52	K51
				Bus 9	Bus 8	Bus 7	Bus 6	Bus 5

Control/ Status Register	Bypass Matrix Bus 'C' to Output Bus (lower bus bits 4-0)							
	Bit 7 (MSB)	Bit 6	Bit 5	Bit 4	Bit 3	Bit 2	Bit 1	Bit 0 (LSB)
Reg. 05A	NC	NC	NC	K50	K49	K48	K47	K46
				Bus 4	Bus 3	Bus 2	Bus 1	Bus 0

Control/ Status Register	Bypass Matrix Bus 'C' to Output Bus (upper bus bits 9-5)							
	Bit 7 (MSB)	Bit 6	Bit 5	Bit 4	Bit 3	Bit 2	Bit 1	Bit 0 (LSB)
Reg. 05B	NC	NC	NC	K60	K59	K58	K57	K56
				Bus 9	Bus 8	Bus 7	Bus 6	Bus 5

Control/ Status Register	Matrix Bus 'A' Stub Break 1 (lower bus bits 4-0)							
	Bit 7 (MSB)	Bit 6	Bit 5	Bit 4	Bit 3	Bit 2	Bit 1	Bit 0 (LSB)
Reg. 06A	NC	NC	NC	K65	K64	K63	K62	K61
				Bus 4	Bus 3	Bus 2	Bus 1	Bus 0

Control/ Status Register	Matrix Bus 'A' Stub Break 1 (upper bus bits 9-5)							
	Bit 7 (MSB)	Bit 6	Bit 5	Bit 4	Bit 3	Bit 2	Bit 1	Bit 0 (LSB)
Reg. 06B	NC	NC	NC	K85	K84	K83	K82	K81
				Bus 9	Bus 8	Bus 7	Bus 6	Bus 5

Control/ Status Register	Matrix Bus 'A' Stub Break 2 (lower bus bits 4-0)							
	Bit 7 (MSB)	Bit 6	Bit 5	Bit 4	Bit 3	Bit 2	Bit 1	Bit 0 (LSB)
Reg. 07A	NC	NC	NC	K70	K69	K68	K67	K66
				Bus 4	Bus 3	Bus 2	Bus 1	Bus 0

Control/ Status Register	Matrix Bus 'A' Stub Break 2 (upper bus bits 9-5)							
	Bit 7 (MSB)	Bit 6	Bit 5	Bit 4	Bit 3	Bit 2	Bit 1	Bit 0 (LSB)
Reg. 07B	NC	NC	NC	K90	K89	K88	K87	K86
				Bus 9	Bus 8	Bus 7	Bus 6	Bus 5

Control/ Status Register	Matrix Bus 'A' Stub Break 3 (lower bus bits 4-0)							
	Bit 7 (MSB)	Bit 6	Bit 5	Bit 4	Bit 3	Bit 2	Bit 1	Bit 0 (LSB)
Reg. 08A	NC	NC	NC	K79	K77	K75	K73	K71
				Bus 4	Bus 3	Bus 2	Bus 1	Bus 0

Control/ Status Register	Matrix Bus 'A' Stub Break 3 (upper bus bits 9-5)							
	Bit 7 (MSB)	Bit 6	Bit 5	Bit 4	Bit 3	Bit 2	Bit 1	Bit 0 (LSB)
Reg. 08B	NC	NC	NC	K99	K97	K95	K93	K91
				Bus 9	Bus 8	Bus 7	Bus 6	Bus 5

Control/ Status Register	Matrix Bus 'A' Stub Break 4 (lower bus bits 4-0)							
	Bit 7 (MSB)	Bit 6	Bit 5	Bit 4	Bit 3	Bit 2	Bit 1	Bit 0 (LSB)
Reg. 09A	NC	NC	NC	K80	K78	K76	K74	K72
				Bus 4	Bus 3	Bus 2	Bus 1	Bus 0

Control/ Status Register	Matrix Bus 'A' Stub Break 4 (upper bus bits 9-5)							
	Bit 7 (MSB)	Bit 6	Bit 5	Bit 4	Bit 3	Bit 2	Bit 1	Bit 0 (LSB)
Reg. 09B	NC	NC	NC	K100	K98	K96	K94	K92
				Bus 9	Bus 8	Bus 7	Bus 6	Bus 5

Control/ Status Register	Matrix Bus 'B' Stub Break 1 (lower bus bits 4-0)							
	Bit 7 (MSB)	Bit 6	Bit 5	Bit 4	Bit 3	Bit 2	Bit 1	Bit 0 (LSB)
Reg. 10A	NC	NC	NC	K105	K104	K103	K102	K101
				Bus 4	Bus 3	Bus 2	Bus 1	Bus 0

Control/ Status Register	Matrix Bus 'B' Stub Break 1 (upper bus bits 9-5)							
	Bit 7 (MSB)	Bit 6	Bit 5	Bit 4	Bit 3	Bit 2	Bit 1	Bit 0 (LSB)
Reg. 10B	NC	NC	NC	K125	K124	K123	K122	K121
				Bus 9	Bus 8	Bus 7	Bus 6	Bus 5

Control/ Status Register	Matrix Bus 'B' Stub Break 2 (lower bus bits 4-0)							
	Bit 7 (MSB)	Bit 6	Bit 5	Bit 4	Bit 3	Bit 2	Bit 1	Bit 0 (LSB)
Reg. 11A	NC	NC	NC	K110	K109	K108	K107	K106
				Bus 4	Bus 3	Bus 2	Bus 1	Bus 0

Control/ Status Register	Matrix Bus 'B' Stub Break 2 (upper bus bits 9-5)							
	Bit 7 (MSB)	Bit 6	Bit 5	Bit 4	Bit 3	Bit 2	Bit 1	Bit 0 (LSB)
Reg. 11B	NC	NC	NC	K130	K129	K128	K127	K126
				Bus 9	Bus 8	Bus 7	Bus 6	Bus 5

Control/ Status Register	Matrix Bus 'B' Stub Break 3 (lower bus bits 4-0)							
	Bit 7 (MSB)	Bit 6	Bit 5	Bit 4	Bit 3	Bit 2	Bit 1	Bit 0 (LSB)
Reg. 12A	NC	NC	NC	K119	K117	K115	K113	K111
				Bus 4	Bus 3	Bus 2	Bus 1	Bus 0

Control/ Status Register	Matrix Bus 'B' Stub Break 3 (upper bus bits 9-5)							
	Bit 7 (MSB)	Bit 6	Bit 5	Bit 4	Bit 3	Bit 2	Bit 1	Bit 0 (LSB)
Reg. 12B	NC	NC	NC	K139	K137	K135	K133	K131
				Bus 9	Bus 8	Bus 7	Bus 6	Bus 5

Control/ Status Register	Matrix Bus 'B' Stub Break 4 (lower bus bits 4-0)							
	Bit 7 (MSB)	Bit 6	Bit 5	Bit 4	Bit 3	Bit 2	Bit 1	Bit 0 (LSB)
Reg. 13A	NC	NC	NC	K120	K118	K116	K114	K112
				Bus 4	Bus 3	Bus 2	Bus 1	Bus 0

Control/ Status Register	Matrix Bus 'B' Stub Break 4 (upper bus bits 9-5)							
	Bit 7 (MSB)	Bit 6	Bit 5	Bit 4	Bit 3	Bit 2	Bit 1	Bit 0 (LSB)
Reg. 13B	NC	NC	NC	K140	K138	K136	K134	K132
				Bus 9	Bus 8	Bus 7	Bus 6	Bus 5

Control/ Status Register	Matrix Bus 'C' Stub Break 1 (lower bus bits 4-0)							
	Bit 7 (MSB)	Bit 6	Bit 5	Bit 4	Bit 3	Bit 2	Bit 1	Bit 0 (LSB)
Reg. 14A	NC	NC	NC	K145	K144	K143	K142	K141
				Bus 4	Bus 3	Bus 2	Bus 1	Bus 0

Control/ Status Register	Matrix Bus 'C' Stub Break 1 (upper bus bits 9-5)							
	Bit 7 (MSB)	Bit 6	Bit 5	Bit 4	Bit 3	Bit 2	Bit 1	Bit 0 (LSB)
Reg. 14B	NC	NC	NC	K165	K164	K163	K162	K161
				Bus 9	Bus 8	Bus 7	Bus 6	Bus 5

Control/ Status Register	Matrix Bus 'C' Stub Break 2 (lower bus bits 4-0)							
	Bit 7 (MSB)	Bit 6	Bit 5	Bit 4	Bit 3	Bit 2	Bit 1	Bit 0 (LSB)
Reg. 15A	NC	NC	NC	K150	K149	K148	K147	K146
				Bus 4	Bus 3	Bus 2	Bus 1	Bus 0

Control/ Status Register	Matrix Bus 'C' Stub Break 2 (upper bus bits 9-5)							
	Bit 7 (MSB)	Bit 6	Bit 5	Bit 4	Bit 3	Bit 2	Bit 1	Bit 0 (LSB)
Reg. 15B	NC	NC	NC	K170	K169	K168	K167	K166
				Bus 9	Bus 8	Bus 7	Bus 6	Bus 5

Control/ Status Register	Matrix Bus 'C' Stub Break 3 (lower bus bits 4-0)							
	Bit 7 (MSB)	Bit 6	Bit 5	Bit 4	Bit 3	Bit 2	Bit 1	Bit 0 (LSB)
Reg. 16A	NC	NC	NC	K159	K157	K155	K153	K151
				Bus 4	Bus 3	Bus 2	Bus 1	Bus 0

Control/ Status Register	Matrix Bus 'C' Stub Break 3 (upper bus bits 9-5)							
	Bit 7 (MSB)	Bit 6	Bit 5	Bit 4	Bit 3	Bit 2	Bit 1	Bit 0 (LSB)
Reg. 16B	NC	NC	NC	K179	K177	K175	K173	K171
				Bus 9	Bus 8	Bus 7	Bus 6	Bus 5

Control/ Status Register	Matrix Bus 'C' Stub Break 4 (lower bus bits 4-0)							
	Bit 7 (MSB)	Bit 6	Bit 5	Bit 4	Bit 3	Bit 2	Bit 1	Bit 0 (LSB)
Reg. 17A	NC	NC	NC	K160	K158	K156	K154	K152
				Bus 4	Bus 3	Bus 2	Bus 1	Bus 0

Control/ Status Register	Matrix Bus 'C' Stub Break 4 (upper bus bits 9-5)							
	Bit 7 (MSB)	Bit 6	Bit 5	Bit 4	Bit 3	Bit 2	Bit 1	Bit 0 (LSB)
Reg. 17B	NC	NC	NC	K180	K178	K176	K174	K172
				Bus 9	Bus 8	Bus 7	Bus 6	Bus 5

Control/ Status Register	Matrix Bus 'A' Pull-up/Pull-down for Load 1							
	Bit 7 (MSB)	Bit 6	Bit 5	Bit 4	Bit 3	Bit 2	Bit 1	Bit 0 (LSB)
Reg. 18A	NC	NC	NC	K185	K184	K183	K182	K181
				Bus 4	Bus 3	Bus 2	Bus 1	Bus 0

Control/ Status Register	Matrix Bus 'A' Pull-up/Pull-down for Load 2							
	Bit 7 (MSB)	Bit 6	Bit 5	Bit 4	Bit 3	Bit 2	Bit 1	Bit 0 (LSB)
Reg. 18B	NC	NC	NC	K195	K194	K193	K192	K191
				Bus 9	Bus 8	Bus 7	Bus 6	Bus 5

Control/ Status Register	Matrix Bus 'A' Resistor Selection for Load 1							
	Bit 7 (MSB)	Bit 6	Bit 5	Bit 4	Bit 3	Bit 2	Bit 1	Bit 0 (LSB)
Reg. 19A	NC	NC	NC	K190	K189	K188	K187	K186
				Bus 4	Bus 3	Bus 2	Bus 1	Bus 0

Control/ Status Register	Matrix Bus 'A' Resistor Selection for Load 2							
	Bit 7 (MSB)	Bit 6	Bit 5	Bit 4	Bit 3	Bit 2	Bit 1	Bit 0 (LSB)
Reg. 19B	NC	NC	NC	K200	K199	K198	K197	K196
				Bus 9	Bus 8	Bus 7	Bus 6	Bus 5

Control/ Status Register	Matrix Bus 'A' Load 1 Connection (lower bus bits 4-0)							
	Bit 7 (MSB)	Bit 6	Bit 5	Bit 4	Bit 3	Bit 2	Bit 1	Bit 0 (LSB)
Reg. 20A	NC	NC	NC	K205	K204	K203	K202	K201
				Bus 4	Bus 3	Bus 2	Bus 1	Bus 0

Control/ Status Register	Matrix Bus 'A' Load 1 Connection (upper bus bits 9-5)							
	Bit 7 (MSB)	Bit 6	Bit 5	Bit 4	Bit 3	Bit 2	Bit 1	Bit 0 (LSB)
Reg. 20B	NC	NC	NC	K210	K209	K208	K207	K206
				Bus 9	Bus 8	Bus 7	Bus 6	Bus 5

Control/ Status Register	Matrix Bus 'A' Load 2 Connection (lower bus bits 4-0)							
	Bit 7 (MSB)	Bit 6	Bit 5	Bit 4	Bit 3	Bit 2	Bit 1	Bit 0 (LSB)
Reg. 21A	NC	NC	NC	K215	K214	K213	K212	K211
				Bus 4	Bus 3	Bus 2	Bus 1	Bus 0

Control/ Status Register	Matrix Bus 'A' Load 2 Connection (upper bus bits 9-5)							
	Bit 7 (MSB)	Bit 6	Bit 5	Bit 4	Bit 3	Bit 2	Bit 1	Bit 0 (LSB)
Reg. 21B	NC	NC	NC	K220	K219	K218	K217	K216
				Bus 9	Bus 8	Bus 7	Bus 6	Bus 5

Control/ Status Register	Matrix Bus 'B' Pull-up/Pull-down for Load 1							
	Bit 7 (MSB)	Bit 6	Bit 5	Bit 4	Bit 3	Bit 2	Bit 1	Bit 0 (LSB)
Reg. 22A	NC	NC	NC	K225	K224	K223	K222	K221
				Bus 4	Bus 3	Bus 2	Bus 1	Bus 0

Control/ Status Register	Matrix Bus 'B' Pull-up/Pull-down for Load 2							
	Bit 7 (MSB)	Bit 6	Bit 5	Bit 4	Bit 3	Bit 2	Bit 1	Bit 0 (LSB)
Reg. 22B	NC	NC	NC	K235	K234	K233	K232	K231
				Bus 9	Bus 8	Bus 7	Bus 6	Bus 5

Control/ Status Register	Matrix Bus 'B' Resistor Selection for Load 1							
	Bit 7 (MSB)	Bit 6	Bit 5	Bit 4	Bit 3	Bit 2	Bit 1	Bit 0 (LSB)
Reg. 23A	NC	NC	NC	K230	K229	K228	K227	K226
				Bus 4	Bus 3	Bus 2	Bus 1	Bus 0

Control/ Status Register	Matrix Bus 'B' Resistor Selection for Load 2							
	Bit 7 (MSB)	Bit 6	Bit 5	Bit 4	Bit 3	Bit 2	Bit 1	Bit 0 (LSB)
Reg. 23B	NC	NC	NC	K240	K239	K238	K237	K236
				Bus 9	Bus 8	Bus 7	Bus 6	Bus 5

Control/ Status Register	Matrix Bus 'B' Load 1 Connection (lower bus bits 4-0)							
	Bit 7 (MSB)	Bit 6	Bit 5	Bit 4	Bit 3	Bit 2	Bit 1	Bit 0 (LSB)
Reg. 24A	NC	NC	NC	K245	K244	K243	K242	K241
				Bus 4	Bus 3	Bus 2	Bus 1	Bus 0

Control/ Status Register	Matrix Bus 'B' Load 1 Connection (upper bus bits 9-5)							
	Bit 7 (MSB)	Bit 6	Bit 5	Bit 4	Bit 3	Bit 2	Bit 1	Bit 0 (LSB)
Reg. 24B	NC	NC	NC	K250	K249	K248	K247	K246
				Bus 9	Bus 8	Bus 7	Bus 6	Bus 5

Control/ Status Register	Matrix Bus 'B' Load 2 Connection (lower bus bits 4-0)							
	Bit 7 (MSB)	Bit 6	Bit 5	Bit 4	Bit 3	Bit 2	Bit 1	Bit 0 (LSB)
Reg. 25A	NC	NC	NC	K255	K254	K253	K252	K251
				Bus 4	Bus 3	Bus 2	Bus 1	Bus 0

Control/ Status Register	Matrix Bus 'B' Load 2 Connection (upper bus bits 9-5)							
	Bit 7 (MSB)	Bit 6	Bit 5	Bit 4	Bit 3	Bit 2	Bit 1	Bit 0 (LSB)
Reg. 25B	NC	NC	NC	K260	K259	K258	K257	K256
				Bus 9	Bus 8	Bus 7	Bus 6	Bus 5

Control/ Status Register	Matrix Bus 'C' Pull-up/Pull-down for Load 1							
	Bit 7 (MSB)	Bit 6	Bit 5	Bit 4	Bit 3	Bit 2	Bit 1	Bit 0 (LSB)
Reg. 26A	NC	NC	NC	K265	K264	K263	K262	K261
				Bus 4	Bus 3	Bus 2	Bus 1	Bus 0

Control/ Status Register	Matrix Bus 'C' Pull-up/Pull-down for Load 2							
	Bit 7 (MSB)	Bit 6	Bit 5	Bit 4	Bit 3	Bit 2	Bit 1	Bit 0 (LSB)
Reg. 26B	NC	NC	NC	K275	K274	K273	K272	K271
				Bus 9	Bus 8	Bus 7	Bus 6	Bus 5

Control/ Status Register	Matrix Bus 'C' Resistor Selection for Load 1							
	Bit 7 (MSB)	Bit 6	Bit 5	Bit 4	Bit 3	Bit 2	Bit 1	Bit 0 (LSB)
Reg. 27A	NC	NC	NC	K270	K269	K268	K267	K266
				Bus 4	Bus 3	Bus 2	Bus 1	Bus 0

Control/ Status Register	Matrix Bus 'C' Resistor Selection for Load 2							
	Bit 7 (MSB)	Bit 6	Bit 5	Bit 4	Bit 3	Bit 2	Bit 1	Bit 0 (LSB)
Reg. 27B	NC	NC	NC	K280	K279	K278	K277	K276
				Bus 9	Bus 8	Bus 7	Bus 6	Bus 5

Control/ Status Register	Matrix Bus 'C' Load 1 Connection (lower bus bits 4-0)							
	Bit 7 (MSB)	Bit 6	Bit 5	Bit 4	Bit 3	Bit 2	Bit 1	Bit 0 (LSB)
Reg. 28A	NC	NC	NC	K285	K284	K283	K282	K281
				Bus 4	Bus 3	Bus 2	Bus 1	Bus 0

Control/ Status Register	Matrix Bus 'C' Load 1 Connection (upper bus bits 9-5)							
	Bit 7 (MSB)	Bit 6	Bit 5	Bit 4	Bit 3	Bit 2	Bit 1	Bit 0 (LSB)
Reg. 28B	NC	NC	NC	K290	K289	K288	K287	K286
				Bus 9	Bus 8	Bus 7	Bus 6	Bus 5

Control/ Status Register	Matrix Bus 'C' Load 2 Connection (lower bus bits 4-0)							
	Bit 7 (MSB)	Bit 6	Bit 5	Bit 4	Bit 3	Bit 2	Bit 1	Bit 0 (LSB)
Reg. 29A	NC	NC	NC	K295	K294	K293	K292	K291
				Bus 4	Bus 3	Bus 2	Bus 1	Bus 0

Control/ Status Register	Matrix Bus 'C' Load 2 Connection (upper bus bits 9-5)							
	Bit 7 (MSB)	Bit 6	Bit 5	Bit 4	Bit 3	Bit 2	Bit 1	Bit 0 (LSB)
Reg. 29B	NC	NC	NC	K300	K299	K298	K297	K296
				Bus 9	Bus 8	Bus 7	Bus 6	Bus 5

Control/ Status Register	Matrix Bus 'A' Instrument Input 1 (lower bus bits 4-0)							
	Bit 7 (MSB)	Bit 6	Bit 5	Bit 4	Bit 3	Bit 2	Bit 1	Bit 0 (LSB)
Reg. 30A	NC	NC	NC	K305	K304	K303	K302	K301
				Bus 4	Bus 3	Bus 2	Bus 1	Bus 0

Control/ Status Register	Matrix Bus 'A' Instrument Input 1 (upper bus bits 9-5)							
	Bit 7 (MSB)	Bit 6	Bit 5	Bit 4	Bit 3	Bit 2	Bit 1	Bit 0 (LSB)
Reg. 30B	NC	NC	NC	K310	K309	K308	K307	K306
				Bus 9	Bus 8	Bus 7	Bus 6	Bus 5

Control/ Status Register	Matrix Bus 'A' Instrument Input 2 (lower bus bits 4-0)							
	Bit 7 (MSB)	Bit 6	Bit 5	Bit 4	Bit 3	Bit 2	Bit 1	Bit 0 (LSB)
Reg. 31A	NC	NC	NC	K315	K314	K313	K312	K311
				Bus 4	Bus 3	Bus 2	Bus 1	Bus 0

Control/ Status Register	Matrix Bus 'A' Instrument Input 2 (upper bus bits 9-5)							
	Bit 7 (MSB)	Bit 6	Bit 5	Bit 4	Bit 3	Bit 2	Bit 1	Bit 0 (LSB)
Reg. 31B	NC	NC	NC	K320	K319	K318	K317	K316
				Bus 9	Bus 8	Bus 7	Bus 6	Bus 5

Control/ Status Register	Matrix Bus 'A' Instrument Input 3 (lower bus bits 4-0)							
	Bit 7 (MSB)	Bit 6	Bit 5	Bit 4	Bit 3	Bit 2	Bit 1	Bit 0 (LSB)
Reg. 32A	NC	NC	NC	K325	K324	K323	K322	K321
				Bus 4	Bus 3	Bus 2	Bus 1	Bus 0

Control/ Status Register	Matrix Bus 'A' Instrument Input 3 (upper bus bits 9-5)							
	Bit 7 (MSB)	Bit 6	Bit 5	Bit 4	Bit 3	Bit 2	Bit 1	Bit 0 (LSB)
Reg. 32B	NC	NC	NC	K330	K329	K328	K327	K326
				Bus 9	Bus 8	Bus 7	Bus 6	Bus 5

Control/ Status Register	Matrix Bus 'A' Instrument Input 4 (lower bus bits 4-0)							
	Bit 7 (MSB)	Bit 6	Bit 5	Bit 4	Bit 3	Bit 2	Bit 1	Bit 0 (LSB)
Reg. 33A	NC	NC	NC	K335	K334	K333	K332	K331
				Bus 4	Bus 3	Bus 2	Bus 1	Bus 0

Control/ Status Register	Matrix Bus 'A' Instrument Input 4 (upper bus bits 9-5)							
	Bit 7 (MSB)	Bit 6	Bit 5	Bit 4	Bit 3	Bit 2	Bit 1	Bit 0 (LSB)
Reg. 33B	NC	NC	NC	K340	K339	K338	K337	K336
				Bus 9	Bus 8	Bus 7	Bus 6	Bus 5

Control/ Status Register	Matrix Bus 'A' Instrument Input 5 (lower bus bits 4-0)							
	Bit 7 (MSB)	Bit 6	Bit 5	Bit 4	Bit 3	Bit 2	Bit 1	Bit 0 (LSB)
Reg. 34A	NC	NC	NC	K345	K344	K343	K342	K341
				Bus 4	Bus 3	Bus 2	Bus 1	Bus 0

Control/ Status Register	Matrix Bus 'A' Instrument Input 5 (upper bus bits 9-5)							
	Bit 7 (MSB)	Bit 6	Bit 5	Bit 4	Bit 3	Bit 2	Bit 1	Bit 0 (LSB)
Reg. 34B	NC	NC	NC	K350	K349	K348	K347	K346
				Bus 9	Bus 8	Bus 7	Bus 6	Bus 5

Control/ Status Register	Matrix Bus 'A' Instrument Input 6 (lower bus bits 4-0)							
	Bit 7 (MSB)	Bit 6	Bit 5	Bit 4	Bit 3	Bit 2	Bit 1	Bit 0 (LSB)
Reg. 35A	NC	NC	NC	K355	K354	K353	K352	K351
				Bus 4	Bus 3	Bus 2	Bus 1	Bus 0

Control/ Status Register	Matrix Bus 'A' Instrument Input 6 (upper bus bits 9-5)							
	Bit 7 (MSB)	Bit 6	Bit 5	Bit 4	Bit 3	Bit 2	Bit 1	Bit 0 (LSB)
Reg. 35B	NC	NC	NC	K360	K359	K358	K357	K356
				Bus 9	Bus 8	Bus 7	Bus 6	Bus 5

Control/ Status Register	Matrix Bus 'A' Instrument Input 7 (lower bus bits 4-0)							
	Bit 7 (MSB)	Bit 6	Bit 5	Bit 4	Bit 3	Bit 2	Bit 1	Bit 0 (LSB)
Reg. 36A	NC	NC	NC	K365	K364	K363	K362	K361
				Bus 4	Bus 3	Bus 2	Bus 1	Bus 0

Control/ Status Register	Matrix Bus 'A' Instrument Input 7 (upper bus bits 9-5)							
	Bit 7 (MSB)	Bit 6	Bit 5	Bit 4	Bit 3	Bit 2	Bit 1	Bit 0 (LSB)
Reg. 36B	NC	NC	NC	K370	K369	K368	K367	K366
				Bus 9	Bus 8	Bus 7	Bus 6	Bus 5

Control/ Status Register	Matrix Bus 'A' Instrument Input 8 (lower bus bits 4-0)							
	Bit 7 (MSB)	Bit 6	Bit 5	Bit 4	Bit 3	Bit 2	Bit 1	Bit 0 (LSB)
Reg. 37A	NC	NC	NC	K375	K374	K373	K372	K371
				Bus 4	Bus 3	Bus 2	Bus 1	Bus 0

Control/ Status Register	Matrix Bus 'A' Instrument Input 8 (upper bus bits 9-5)							
	Bit 7 (MSB)	Bit 6	Bit 5	Bit 4	Bit 3	Bit 2	Bit 1	Bit 0 (LSB)
Reg. 37B	NC	NC	NC	K380	K379	K378	K377	K376
				Bus 9	Bus 8	Bus 7	Bus 6	Bus 5

Control/ Status Register	Matrix Bus 'A' Output 1							
	Bit 7 (MSB)	Bit 6	Bit 5	Bit 4	Bit 3	Bit 2	Bit 1	Bit 0 (LSB)
Reg. 38	NC	NC	NC	K385	K384	K383	K382	K381
				Bus 4	Bus 3	Bus 2	Bus 1	Bus 0

Control/ Status Register	Matrix Bus 'A' Output 2							
	Bit 7 (MSB)	Bit 6	Bit 5	Bit 4	Bit 3	Bit 2	Bit 1	Bit 0 (LSB)
Reg. 39	NC	NC	NC	K390	K389	K388	K387	K386
				Bus 7	Bus 3	Bus 2	Bus 1	Bus 0

Control/ Status Register	Matrix Bus 'A' Output 3							
	Bit 7 (MSB)	Bit 6	Bit 5	Bit 4	Bit 3	Bit 2	Bit 1	Bit 0 (LSB)
Reg. 40	NC	NC	NC	K395	K394	K393	K392	K391
				Bus 6	Bus 3	Bus 2	Bus 1	Bus 0

Control/ Status Register	Matrix Bus 'A' Output 4							
	Bit 7 (MSB)	Bit 6	Bit 5	Bit 4	Bit 3	Bit 2	Bit 1	Bit 0 (LSB)
Reg. 41	NC	NC	NC	K400	K399	K398	K397	K396
				Bus 6	Bus 4	Bus 2	Bus 1	Bus 0

Control/ Status Register	Matrix Bus 'A' Output 5							
	Bit 7 (MSB)	Bit 6	Bit 5	Bit 4	Bit 3	Bit 2	Bit 1	Bit 0 (LSB)
Reg. 42	NC	NC	NC	K405	K404	K403	K402	K401
				Bus 5	Bus 4	Bus 2	Bus 1	Bus 0

Control/ Status Register	Matrix Bus 'A' Output 6							
	Bit 7 (MSB)	Bit 6	Bit 5	Bit 4	Bit 3	Bit 2	Bit 1	Bit 0 (LSB)
Reg. 43	NC	NC	NC	K410	K409	K408	K407	K406
				Bus 5	Bus 3	Bus 2	Bus 1	Bus 0

Control/ Status Register	Matrix Bus 'A' Output 7							
	Bit 7 (MSB)	Bit 6	Bit 5	Bit 4	Bit 3	Bit 2	Bit 1	Bit 0 (LSB)
Reg. 44	NC	NC	NC	K415	K414	K413	K412	K411
				Bus 7	Bus 6	Bus 2	Bus 1	Bus 0

Control/ Status Register	Matrix Bus 'A' Output 8							
	Bit 7 (MSB)	Bit 6	Bit 5	Bit 4	Bit 3	Bit 2	Bit 1	Bit 0 (LSB)
Reg. 45	NC	NC	NC	K420	K419	K418	K417	K416
				Bus 7	Bus 4	Bus 2	Bus 1	Bus 0

Control/ Status Register	Matrix Bus 'A' Output 9							
	Bit 7 (MSB)	Bit 6	Bit 5	Bit 4	Bit 3	Bit 2	Bit 1	Bit 0 (LSB)
Reg. 46	NC	NC	NC	K425	K424	K423	K422	K421
				Bus 7	Bus 5	Bus 2	Bus 1	Bus 0

Control/ Status Register	Matrix Bus 'A' Output 10							
	Bit 7 (MSB)	Bit 6	Bit 5	Bit 4	Bit 3	Bit 2	Bit 1	Bit 0 (LSB)
Reg. 47	NC	NC	NC	K430	K429	K428	K427	K426
				Bus 5	Bus 4	Bus 3	Bus 1	Bus 0

Control/ Status Register	Matrix Bus 'A' Output 11							
	Bit 7 (MSB)	Bit 6	Bit 5	Bit 4	Bit 3	Bit 2	Bit 1	Bit 0 (LSB)
Reg. 48	NC	NC	NC	K435	K434	K433	K432	K431
				Bus 6	Bus 4	Bus 3	Bus 1	Bus 0

Control/ Status Register	Matrix Bus 'A' Output 12							
	Bit 7 (MSB)	Bit 6	Bit 5	Bit 4	Bit 3	Bit 2	Bit 1	Bit 0 (LSB)
Reg. 49	NC	NC	NC	K440	K439	K438	K437	K436
				Bus 6	Bus 5	Bus 2	Bus 1	Bus 0

Control/ Status Register	Matrix Bus 'A' Output 13							
	Bit 7 (MSB)	Bit 6	Bit 5	Bit 4	Bit 3	Bit 2	Bit 1	Bit 0 (LSB)
Reg. 50	NC	NC	NC	K445	K444	K443	K442	K441
				Bus 6	Bus 4	Bus 3	Bus 2	Bus 0

Control/ Status Register	Matrix Bus 'A' Output 14							
	Bit 7 (MSB)	Bit 6	Bit 5	Bit 4	Bit 3	Bit 2	Bit 1	Bit 0 (LSB)
Reg. 51	NC	NC	NC	K450	K449	K448	K447	K446
				Bus 7	Bus 4	Bus 3	Bus 2	Bus 0

Control/ Status Register	Matrix Bus 'A' Output 15							
	Bit 7 (MSB)	Bit 6	Bit 5	Bit 4	Bit 3	Bit 2	Bit 1	Bit 0 (LSB)
Reg. 52	NC	NC	NC	K455	K454	K453	K452	K451
				Bus 8	Bus 4	Bus 3	Bus 2	Bus 0

Control/ Status Register	Matrix Bus 'A' Output 16							
	Bit 7 (MSB)	Bit 6	Bit 5	Bit 4	Bit 3	Bit 2	Bit 1	Bit 0 (LSB)
Reg. 53	NC	NC	NC	K460	K459	K458	K457	K456
				Bus 8	Bus 5	Bus 3	Bus 2	Bus 0

Control/ Status Register	Matrix Bus 'A' Output 17							
	Bit 7 (MSB)	Bit 6	Bit 5	Bit 4	Bit 3	Bit 2	Bit 1	Bit 0 (LSB)
Reg. 54	NC	NC	NC	K465	K464	K463	K462	K461
				Bus 7	Bus 5	Bus 3	Bus 2	Bus 0

Control/ Status Register	Matrix Bus 'A' Output 18							
	Bit 7 (MSB)	Bit 6	Bit 5	Bit 4	Bit 3	Bit 2	Bit 1	Bit 0 (LSB)
Reg. 55	NC	NC	NC	K470	K469	K468	K467	K466
				Bus 6	Bus 5	Bus 3	Bus 2	Bus 0

Control/ Status Register	Matrix Bus 'A' Output 19							
	Bit 7 (MSB)	Bit 6	Bit 5	Bit 4	Bit 3	Bit 2	Bit 1	Bit 0 (LSB)
Reg. 56	NC	NC	NC	K475	K474	K473	K472	K471
				Bus 8	Bus 3	Bus 2	Bus 1	Bus 0

Control/ Status Register	Matrix Bus 'A' Output 20							
	Bit 7 (MSB)	Bit 6	Bit 5	Bit 4	Bit 3	Bit 2	Bit 1	Bit 0 (LSB)
Reg. 57	NC	NC	NC	K480	K479	K478	K477	K476
				Bus 8	Bus 6	Bus 4	Bus 1	Bus 0

Control/ Status Register	Matrix Bus 'A' Output 21							
	Bit 7 (MSB)	Bit 6	Bit 5	Bit 4	Bit 3	Bit 2	Bit 1	Bit 0 (LSB)
Reg. 58	NC	NC	NC	K485	K484	K483	K482	K481
				Bus 7	Bus 4	Bus 3	Bus 1	Bus 0

Control/ Status Register	Matrix Bus 'A' Output 22							
	Bit 7 (MSB)	Bit 6	Bit 5	Bit 4	Bit 3	Bit 2	Bit 1	Bit 0 (LSB)
Reg. 59	NC	NC	NC	K490	K489	K488	K487	K486
				Bus 7	Bus 6	Bus 3	Bus 1	Bus 0

Control/ Status Register	Matrix Bus 'A' Output 23							
	Bit 7 (MSB)	Bit 6	Bit 5	Bit 4	Bit 3	Bit 2	Bit 1	Bit 0 (LSB)
Reg. 60	NC	NC	NC	K495	K494	K493	K492	K491
				Bus 6	Bus 5	Bus 3	Bus 1	Bus 0

Control/ Status Register	Matrix Bus 'A' Output 24							
	Bit 7 (MSB)	Bit 6	Bit 5	Bit 4	Bit 3	Bit 2	Bit 1	Bit 0 (LSB)
Reg. 61	NC	NC	NC	K500	K499	K498	K497	K496
				Bus 7	Bus 5	Bus 3	Bus 1	Bus 0

Control/ Status Register	Matrix Bus 'B' Instrument Input 1 (lower bus bits 4-0)							
	Bit 7 (MSB)	Bit 6	Bit 5	Bit 4	Bit 3	Bit 2	Bit 1	Bit 0 (LSB)
Reg. 62A	NC	NC	NC	K505	K504	K503	K502	K501
				Bus 4	Bus 3	Bus 2	Bus 1	Bus 0

Control/ Status Register	Matrix Bus 'B' Instrument Input 1 (upper bus bits 9-5)							
	Bit 7 (MSB)	Bit 6	Bit 5	Bit 4	Bit 3	Bit 2	Bit 1	Bit 0 (LSB)
Reg. 62B	NC	NC	NC	K510	K509	K508	K507	K506
				Bus 9	Bus 8	Bus 7	Bus 6	Bus 5

Control/ Status Register	Matrix Bus 'B' Instrument Input 2 (lower bus bits 4-0)							
	Bit 7 (MSB)	Bit 6	Bit 5	Bit 4	Bit 3	Bit 2	Bit 1	Bit 0 (LSB)
Reg. 63A	NC	NC	NC	K515	K514	K513	K512	K511
				Bus 4	Bus 3	Bus 2	Bus 1	Bus 0

Control/ Status Register	Matrix Bus 'B' Instrument Input 2 (upper bus bits 9-5)							
	Bit 7 (MSB)	Bit 6	Bit 5	Bit 4	Bit 3	Bit 2	Bit 1	Bit 0 (LSB)
Reg. 63B	NC	NC	NC	K520	K519	K518	K517	K516
				Bus 9	Bus 8	Bus 7	Bus 6	Bus 5

Control/ Status Register	Matrix Bus 'B' Instrument Input 3 (lower bus bits 4-0)							
	Bit 7 (MSB)	Bit 6	Bit 5	Bit 4	Bit 3	Bit 2	Bit 1	Bit 0 (LSB)
Reg. 64A	NC	NC	NC	K525	K524	K523	K522	K521
				Bus 4	Bus 3	Bus 2	Bus 1	Bus 0

Control/ Status Register	Matrix Bus 'B' Instrument Input 3 (upper bus bits 9-5)							
	Bit 7 (MSB)	Bit 6	Bit 5	Bit 4	Bit 3	Bit 2	Bit 1	Bit 0 (LSB)
Reg. 64B	NC	NC	NC	K530	K529	K528	K527	K526
				Bus 9	Bus 8	Bus 7	Bus 6	Bus 5

Control/ Status Register	Matrix Bus 'B' Instrument Input 4 (lower bus bits 4-0)							
	Bit 7 (MSB)	Bit 6	Bit 5	Bit 4	Bit 3	Bit 2	Bit 1	Bit 0 (LSB)
Reg. 65A	NC	NC	NC	K535	K534	K533	K532	K531
				Bus 4	Bus 3	Bus 2	Bus 1	Bus 0

Control/ Status Register	Matrix Bus 'B' Instrument Input 4 (upper bus bits 9-5)							
	Bit 7 (MSB)	Bit 6	Bit 5	Bit 4	Bit 3	Bit 2	Bit 1	Bit 0 (LSB)
Reg. 65B	NC	NC	NC	K540	K539	K538	K537	K536
				Bus 9	Bus 8	Bus 7	Bus 6	Bus 5

Control/ Status Register	Matrix Bus 'B' Instrument Input 5 (lower bus bits 4-0)							
	Bit 7 (MSB)	Bit 6	Bit 5	Bit 4	Bit 3	Bit 2	Bit 1	Bit 0 (LSB)
Reg. 66A	NC	NC	NC	K545	K544	K543	K542	K541
				Bus 4	Bus 3	Bus 2	Bus 1	Bus 0

Control/ Status Register	Matrix Bus 'B' Instrument Input 5 (upper bus bits 9-5)							
	Bit 7 (MSB)	Bit 6	Bit 5	Bit 4	Bit 3	Bit 2	Bit 1	Bit 0 (LSB)
Reg. 66B	NC	NC	NC	K550	K549	K548	K547	K546
				Bus 9	Bus 8	Bus 7	Bus 6	Bus 5

Control/ Status Register	Matrix Bus 'B' Instrument Input 6 (lower bus bits 4-0)							
	Bit 7 (MSB)	Bit 6	Bit 5	Bit 4	Bit 3	Bit 2	Bit 1	Bit 0 (LSB)
Reg. 67A	NC	NC	NC	K555	K554	K553	K552	K551
				Bus 4	Bus 3	Bus 2	Bus 1	Bus 0

Control/ Status Register	Matrix Bus 'B' Instrument Input 6 (upper bus bits 9-5)							
	Bit 7 (MSB)	Bit 6	Bit 5	Bit 4	Bit 3	Bit 2	Bit 1	Bit 0 (LSB)
Reg. 67B	NC	NC	NC	K560	K559	K558	K557	K556
				Bus 9	Bus 8	Bus 7	Bus 6	Bus 5

Control/ Status Register	Matrix Bus 'B' Instrument Input 7 (lower bus bits 4-0)							
	Bit 7 (MSB)	Bit 6	Bit 5	Bit 4	Bit 3	Bit 2	Bit 1	Bit 0 (LSB)
Reg. 68A	NC	NC	NC	K565	K564	K563	K562	K561
				Bus 4	Bus 3	Bus 2	Bus 1	Bus 0

Control/ Status Register	Matrix Bus 'B' Instrument Input 7 (upper bus bits 9-5)							
	Bit 7 (MSB)	Bit 6	Bit 5	Bit 4	Bit 3	Bit 2	Bit 1	Bit 0 (LSB)
Reg. 68B	NC	NC	NC	K570	K569	K568	K567	K566
				Bus 9	Bus 8	Bus 7	Bus 6	Bus 5

Control/ Status Register	Matrix Bus 'B' Instrument Input 8 (lower bus bits 4-0)							
	Bit 7 (MSB)	Bit 6	Bit 5	Bit 4	Bit 3	Bit 2	Bit 1	Bit 0 (LSB)
Reg. 69A	NC	NC	NC	K575	K574	K573	K572	K571
				Bus 4	Bus 3	Bus 2	Bus 1	Bus 0

Control/ Status Register	Matrix Bus 'B' Instrument Input 8 (upper bus bits 9-5)							
	Bit 7 (MSB)	Bit 6	Bit 5	Bit 4	Bit 3	Bit 2	Bit 1	Bit 0 (LSB)
Reg. 69B	NC	NC	NC	K580	K579	K578	K577	K576
				Bus 9	Bus 8	Bus 7	Bus 6	Bus 5

Control/ Status Register	Matrix Bus 'B' Output 1							
	Bit 7 (MSB)	Bit 6	Bit 5	Bit 4	Bit 3	Bit 2	Bit 1	Bit 0 (LSB)
Reg. 70	NC	NC	NC	K585	K584	K583	K582	K581
				Bus 5	Bus 4	Bus 3	Bus 2	Bus 1

Control/ Status Register	Matrix Bus 'B' Output 2							
	Bit 7 (MSB)	Bit 6	Bit 5	Bit 4	Bit 3	Bit 2	Bit 1	Bit 0 (LSB)
Reg. 71	NC	NC	NC	K590	K589	K588	K587	K586
				Bus 8	Bus 4	Bus 3	Bus 2	Bus 1

Control/ Status Register	Matrix Bus 'B' Output 3							
	Bit 7 (MSB)	Bit 6	Bit 5	Bit 4	Bit 3	Bit 2	Bit 1	Bit 0 (LSB)
Reg. 72	NC	NC	NC	K595	K594	K593	K592	K591
				Bus 7	Bus 4	Bus 3	Bus 2	Bus 1

Control/ Status Register	Matrix Bus 'B' Output 4							
	Bit 7 (MSB)	Bit 6	Bit 5	Bit 4	Bit 3	Bit 2	Bit 1	Bit 0 (LSB)
Reg. 73	NC	NC	NC	K600	K599	K598	K597	K596
				Bus 7	Bus 5	Bus 3	Bus 2	Bus 1

Control/ Status Register	Matrix Bus 'B' Output 5							
	Bit 7 (MSB)	Bit 6	Bit 5	Bit 4	Bit 3	Bit 2	Bit 1	Bit 0 (LSB)
Reg. 74	NC	NC	NC	K605	K604	K603	K602	K601
				Bus 6	Bus 5	Bus 3	Bus 2	Bus 1

Control/ Status Register	Matrix Bus 'B' Output 6							
	Bit 7 (MSB)	Bit 6	Bit 5	Bit 4	Bit 3	Bit 2	Bit 1	Bit 0 (LSB)
Reg. 75	NC	NC	NC	K610	K609	K608	K607	K606
				Bus 6	Bus 4	Bus 3	Bus 2	Bus 1

Control/ Status Register	Matrix Bus 'B' Output 7							
	Bit 7 (MSB)	Bit 6	Bit 5	Bit 4	Bit 3	Bit 2	Bit 1	Bit 0 (LSB)
Reg. 76	NC	NC	NC	K615	K614	K613	K612	K611
				Bus 8	Bus 7	Bus 3	Bus 2	Bus 1

Control/ Status Register	Matrix Bus 'B' Output 8							
	Bit 7 (MSB)	Bit 6	Bit 5	Bit 4	Bit 3	Bit 2	Bit 1	Bit 0 (LSB)
Reg. 77	NC	NC	NC	K620	K619	K618	K617	K616
				Bus 8	Bus 5	Bus 3	Bus 2	Bus 1

Control/ Status Register	Matrix Bus 'B' Output 9							
	Bit 7 (MSB)	Bit 6	Bit 5	Bit 4	Bit 3	Bit 2	Bit 1	Bit 0 (LSB)
Reg. 78	NC	NC	NC	K625	K624	K623	K622	K621
				Bus 8	Bus 6	Bus 3	Bus 2	Bus 1

Control/ Status Register	Matrix Bus 'B' Output 10							
	Bit 7 (MSB)	Bit 6	Bit 5	Bit 4	Bit 3	Bit 2	Bit 1	Bit 0 (LSB)
Reg. 79	NC	NC	NC	K630	K629	K628	K627	K626
				Bus 6	Bus 5	Bus 4	Bus 2	Bus 1

Control/ Status Register	Matrix Bus 'B' Output 11							
	Bit 7 (MSB)	Bit 6	Bit 5	Bit 4	Bit 3	Bit 2	Bit 1	Bit 0 (LSB)
Reg. 80	NC	NC	NC	K635	K634	K633	K632	K631
				Bus 7	Bus 5	Bus 4	Bus 2	Bus 1

Control/ Status Register	Matrix Bus 'B' Output 12							
	Bit 7 (MSB)	Bit 6	Bit 5	Bit 4	Bit 3	Bit 2	Bit 1	Bit 0 (LSB)
Reg. 81	NC	NC	NC	K640	K639	K638	K637	K636
				Bus 7	Bus 6	Bus 3	Bus 2	Bus 1

Control/ Status Register	Matrix Bus 'B' Output 13							
	Bit 7 (MSB)	Bit 6	Bit 5	Bit 4	Bit 3	Bit 2	Bit 1	Bit 0 (LSB)
Reg. 82	NC	NC	NC	K645	K644	K643	K642	K641
				Bus 7	Bus 5	Bus 4	Bus 3	Bus 1

Control/ Status Register	Matrix Bus 'B' Output 14							
	Bit 7 (MSB)	Bit 6	Bit 5	Bit 4	Bit 3	Bit 2	Bit 1	Bit 0 (LSB)
Reg. 83	NC	NC	NC	K650	K649	K648	K647	K646
				Bus 8	Bus 5	Bus 4	Bus 3	Bus 1

Control/ Status Register	Matrix Bus 'B' Output 15							
	Bit 7 (MSB)	Bit 6	Bit 5	Bit 4	Bit 3	Bit 2	Bit 1	Bit 0 (LSB)
Reg. 84	NC	NC	NC	K655	K654	K653	K652	K651
				Bus 9	Bus 5	Bus 4	Bus 3	Bus 1

Control/ Status Register	Matrix Bus 'B' Output 16							
	Bit 7 (MSB)	Bit 6	Bit 5	Bit 4	Bit 3	Bit 2	Bit 1	Bit 0 (LSB)
Reg. 85	NC	NC	NC	K660	K659	K658	K657	K656
				Bus 9	Bus 6	Bus 4	Bus 3	Bus 1

Control/ Status Register	Matrix Bus 'B' Output 17							
	Bit 7 (MSB)	Bit 6	Bit 5	Bit 4	Bit 3	Bit 2	Bit 1	Bit 0 (LSB)
Reg. 86	NC	NC	NC	K665	K664	K663	K662	K661
				Bus 8	Bus 6	Bus 4	Bus 3	Bus 1

Control/ Status Register	Matrix Bus 'B' Output 18							
	Bit 7 (MSB)	Bit 6	Bit 5	Bit 4	Bit 3	Bit 2	Bit 1	Bit 0 (LSB)
Reg. 87	NC	NC	NC	K670	K669	K668	K667	K666
				Bus 7	Bus 6	Bus 4	Bus 3	Bus 1

Control/ Status Register	Matrix Bus 'B' Output 19							
	Bit 7 (MSB)	Bit 6	Bit 5	Bit 4	Bit 3	Bit 2	Bit 1	Bit 0 (LSB)
Reg. 88	NC	NC	NC	K675	K674	K673	K672	K671
				Bus 9	Bus 4	Bus 3	Bus 2	Bus 1

Control/ Status Register	Matrix Bus 'B' Output 20							
	Bit 7 (MSB)	Bit 6	Bit 5	Bit 4	Bit 3	Bit 2	Bit 1	Bit 0 (LSB)
Reg. 89	NC	NC	NC	K680	K679	K678	K677	K676
				Bus 9	Bus 7	Bus 5	Bus 2	Bus 1

Control/ Status Register	Matrix Bus 'B' Output 21							
	Bit 7 (MSB)	Bit 6	Bit 5	Bit 4	Bit 3	Bit 2	Bit 1	Bit 0 (LSB)
Reg. 90	NC	NC	NC	K685	K684	K683	K682	K681
				Bus 8	Bus 5	Bus 4	Bus 2	Bus 1

Control/ Status Register	Matrix Bus 'B' Output 22							
	Bit 7 (MSB)	Bit 6	Bit 5	Bit 4	Bit 3	Bit 2	Bit 1	Bit 0 (LSB)
Reg. 91	NC	NC	NC	K690	K689	K688	K687	K686
				Bus 8	Bus 7	Bus 4	Bus 2	Bus 1

Control/ Status Register	Matrix Bus 'B' Output 23							
	Bit 7 (MSB)	Bit 6	Bit 5	Bit 4	Bit 3	Bit 2	Bit 1	Bit 0 (LSB)
Reg. 92	NC	NC	NC	K695	K694	K693	K692	K691
				Bus 7	Bus 6	Bus 4	Bus 2	Bus 1

Control/ Status Register	Matrix Bus 'B' Output 24							
	Bit 7 (MSB)	Bit 6	Bit 5	Bit 4	Bit 3	Bit 2	Bit 1	Bit 0 (LSB)
Reg. 93	NC	NC	NC	K700	K699	K698	K697	K696
				Bus 8	Bus 6	Bus 4	Bus 2	Bus 1

Control/ Status Register	Matrix Bus 'C' Instrument Input 1 (lower bus bits 4-0)							
	Bit 7 (MSB)	Bit 6	Bit 5	Bit 4	Bit 3	Bit 2	Bit 1	Bit 0 (LSB)
Reg. 94A	NC	NC	NC	K705	K704	K703	K702	K701
				Bus 4	Bus 3	Bus 2	Bus 1	Bus 0

Control/ Status Register	Matrix Bus 'C' Instrument Input 1 (upper bus bits 9-5)							
	Bit 7 (MSB)	Bit 6	Bit 5	Bit 4	Bit 3	Bit 2	Bit 1	Bit 0 (LSB)
Reg. 94B	NC	NC	NC	K710	K709	K708	K707	K706
				Bus 9	Bus 8	Bus 7	Bus 6	Bus 5

Control/ Status Register	Matrix Bus 'C' Instrument Input 2 (lower bus bits 4-0)							
	Bit 7 (MSB)	Bit 6	Bit 5	Bit 4	Bit 3	Bit 2	Bit 1	Bit 0 (LSB)
Reg. 95A	NC	NC	NC	K715	K714	K713	K712	K711
				Bus 4	Bus 3	Bus 2	Bus 1	Bus 0

Control/ Status Register	Matrix Bus 'C' Instrument Input 2 (upper bus bits 9-5)							
	Bit 7 (MSB)	Bit 6	Bit 5	Bit 4	Bit 3	Bit 2	Bit 1	Bit 0 (LSB)
Reg. 95B	NC	NC	NC	K720	K719	K718	K717	K716
				Bus 9	Bus 8	Bus 7	Bus 6	Bus 5

Control/ Status Register	Matrix Bus 'C' Instrument Input 3 (lower bus bits 4-0)							
	Bit 7 (MSB)	Bit 6	Bit 5	Bit 4	Bit 3	Bit 2	Bit 1	Bit 0 (LSB)
Reg. 96A	NC	NC	NC	K725	K724	K723	K722	K721
				Bus 4	Bus 3	Bus 2	Bus 1	Bus 0

Control/ Status Register	Matrix Bus 'C' Instrument Input 3 (upper bus bits 9-5)							
	Bit 7 (MSB)	Bit 6	Bit 5	Bit 4	Bit 3	Bit 2	Bit 1	Bit 0 (LSB)
Reg. 96B	NC	NC	NC	K730	K729	K728	K727	K726
				Bus 9	Bus 8	Bus 7	Bus 6	Bus 5

Control/ Status Register	Matrix Bus 'C' Instrument Input 4 (lower bus bits 4-0)							
	Bit 7 (MSB)	Bit 6	Bit 5	Bit 4	Bit 3	Bit 2	Bit 1	Bit 0 (LSB)
Reg. 97A	NC	NC	NC	K735	K734	K733	K732	K731
				Bus 4	Bus 3	Bus 2	Bus 1	Bus 0

Control/ Status Register	Matrix Bus 'C' Instrument Input 4 (upper bus bits 9-5)							
	Bit 7 (MSB)	Bit 6	Bit 5	Bit 4	Bit 3	Bit 2	Bit 1	Bit 0 (LSB)
Reg. 97B	NC	NC	NC	K740	K739	K738	K737	K736
				Bus 9	Bus 8	Bus 7	Bus 6	Bus 5

Control/ Status Register	Matrix Bus 'C' Instrument Input 5 (lower bus bits 4-0)							
	Bit 7 (MSB)	Bit 6	Bit 5	Bit 4	Bit 3	Bit 2	Bit 1	Bit 0 (LSB)
Reg. 98A	NC	NC	NC	K745	K744	K743	K742	K741
				Bus 4	Bus 3	Bus 2	Bus 1	Bus 0

Control/ Status Register	Matrix Bus 'C' Instrument Input 5 (upper bus bits 9-5)							
	Bit 7 (MSB)	Bit 6	Bit 5	Bit 4	Bit 3	Bit 2	Bit 1	Bit 0 (LSB)
Reg. 98B	NC	NC	NC	K750	K749	K748	K747	K746
				Bus 9	Bus 8	Bus 7	Bus 6	Bus 5

Control/ Status Register	Matrix Bus 'C' Instrument Input 6 (lower bus bits 4-0)							
	Bit 7 (MSB)	Bit 6	Bit 5	Bit 4	Bit 3	Bit 2	Bit 1	Bit 0 (LSB)
Reg. 99A	NC	NC	NC	K755	K754	K753	K752	K751
				Bus 4	Bus 3	Bus 2	Bus 1	Bus 0

Control/ Status Register	Matrix Bus 'C' Instrument Input 6 (upper bus bits 9-5)							
	Bit 7 (MSB)	Bit 6	Bit 5	Bit 4	Bit 3	Bit 2	Bit 1	Bit 0 (LSB)
Reg. 99B	NC	NC	NC	K760	K759	K758	K757	K756
				Bus 9	Bus 8	Bus 7	Bus 6	Bus 5

Control/ Status Register	Matrix Bus 'C' Instrument Input 7 (lower bus bits 4-0)							
	Bit 7 (MSB)	Bit 6	Bit 5	Bit 4	Bit 3	Bit 2	Bit 1	Bit 0 (LSB)
Reg. 100A	NC	NC	NC	K765	K764	K763	K762	K761
				Bus 4	Bus 3	Bus 2	Bus 1	Bus 0

Control/ Status Register	Matrix Bus 'C' Instrument Input 7 (upper bus bits 9-5)							
	Bit 7 (MSB)	Bit 6	Bit 5	Bit 4	Bit 3	Bit 2	Bit 1	Bit 0 (LSB)
Reg. 100B	NC	NC	NC	K770	K769	K768	K767	K766
				Bus 9	Bus 8	Bus 7	Bus 6	Bus 5

Control/ Status Register	Matrix Bus 'C' Instrument Input 8 (lower bus bits 4-0)							
	Bit 7 (MSB)	Bit 6	Bit 5	Bit 4	Bit 3	Bit 2	Bit 1	Bit 0 (LSB)
Reg. 101A	NC	NC	NC	K775	K774	K773	K772	K771
				Bus 4	Bus 3	Bus 2	Bus 1	Bus 0

Control/ Status Register	Matrix Bus 'C' Instrument Input 8 (upper bus bits 9-5)							
	Bit 7 (MSB)	Bit 6	Bit 5	Bit 4	Bit 3	Bit 2	Bit 1	Bit 0 (LSB)
Reg. 101B	NC	NC	NC	K780	K779	K778	K777	K776
				Bus 9	Bus 8	Bus 7	Bus 6	Bus 5

Control/ Status Register	Matrix Bus 'C' Output 1							
	Bit 7 (MSB)	Bit 6	Bit 5	Bit 4	Bit 3	Bit 2	Bit 1	Bit 0 (LSB)
Reg. 102	NC	NC	NC	K785	K784	K783	K782	K781
				Bus 6	Bus 5	Bus 4	Bus 3	Bus 2

Control/ Status Register	Matrix Bus 'C' Output 2							
	Bit 7 (MSB)	Bit 6	Bit 5	Bit 4	Bit 3	Bit 2	Bit 1	Bit 0 (LSB)
Reg. 103	NC	NC	NC	K790	K789	K788	K787	K786
				Bus 9	Bus 5	Bus 4	Bus 3	Bus 2

Control/ Status Register	Matrix Bus 'C' Output 3							
	Bit 7 (MSB)	Bit 6	Bit 5	Bit 4	Bit 3	Bit 2	Bit 1	Bit 0 (LSB)
Reg. 104	NC	NC	NC	K795	K794	K793	K792	K791
				Bus 8	Bus 5	Bus 4	Bus 3	Bus 2

Control/ Status Register	Matrix Bus 'C' Output 4							
	Bit 7 (MSB)	Bit 6	Bit 5	Bit 4	Bit 3	Bit 2	Bit 1	Bit 0 (LSB)
Reg. 105	NC	NC	NC	K800	K799	K798	K797	K796
				Bus 8	Bus 6	Bus 4	Bus 3	Bus 2

Control/ Status Register	Matrix Bus 'C' Output 5							
	Bit 7 (MSB)	Bit 6	Bit 5	Bit 4	Bit 3	Bit 2	Bit 1	Bit 0 (LSB)
Reg. 106	NC	NC	NC	K805	K804	K803	K802	K801
				Bus 7	Bus 6	Bus 4	Bus 3	Bus 2

Control/ Status Register	Matrix Bus 'C' Output 6							
	Bit 7 (MSB)	Bit 6	Bit 5	Bit 4	Bit 3	Bit 2	Bit 1	Bit 0 (LSB)
Reg. 107	NC	NC	NC	K810	K809	K808	K807	K806
				Bus 7	Bus 5	Bus 4	Bus 3	Bus 2

Control/ Status Register	Matrix Bus 'C' Output 7							
	Bit 7 (MSB)	Bit 6	Bit 5	Bit 4	Bit 3	Bit 2	Bit 1	Bit 0 (LSB)
Reg. 108	NC	NC	NC	K815	K814	K813	K812	K811
				Bus 9	Bus 8	Bus 4	Bus 3	Bus 2

Control/ Status Register	Matrix Bus 'C' Output 8							
	Bit 7 (MSB)	Bit 6	Bit 5	Bit 4	Bit 3	Bit 2	Bit 1	Bit 0 (LSB)
Reg. 109	NC	NC	NC	K820	K819	K818	K817	K816
				Bus 9	Bus 6	Bus 4	Bus 3	Bus 2

Control/ Status Register	Matrix Bus 'C' Output 9							
	Bit 7 (MSB)	Bit 6	Bit 5	Bit 4	Bit 3	Bit 2	Bit 1	Bit 0 (LSB)
Reg. 110	NC	NC	NC	K825	K824	K823	K822	K821
				Bus 9	Bus 7	Bus 4	Bus 3	Bus 2

Control/ Status Register	Matrix Bus 'C' Output 10							
	Bit 7 (MSB)	Bit 6	Bit 5	Bit 4	Bit 3	Bit 2	Bit 1	Bit 0 (LSB)
Reg. 111	NC	NC	NC	K830	K829	K828	K827	K826
				Bus 7	Bus 6	Bus 5	Bus 3	Bus 2

Control/ Status Register	Matrix Bus 'C' Output 11							
	Bit 7 (MSB)	Bit 6	Bit 5	Bit 4	Bit 3	Bit 2	Bit 1	Bit 0 (LSB)
Reg. 112	NC	NC	NC	K835	K834	K833	K832	K831
				Bus 8	Bus 6	Bus 5	Bus 3	Bus 2

Control/ Status Register	Matrix Bus 'C' Output 12							
	Bit 7 (MSB)	Bit 6	Bit 5	Bit 4	Bit 3	Bit 2	Bit 1	Bit 0 (LSB)
Reg. 113	NC	NC	NC	K840	K839	K838	K837	K836
				Bus 8	Bus 7	Bus 4	Bus 3	Bus 2

Control/ Status Register	Matrix Bus 'C' Output 13							
	Bit 7 (MSB)	Bit 6	Bit 5	Bit 4	Bit 3	Bit 2	Bit 1	Bit 0 (LSB)
Reg. 114	NC	NC	NC	K845	K844	K843	K842	K841
				Bus 8	Bus 6	Bus 5	Bus 4	Bus 2

Control/ Status Register	Matrix Bus 'C' Output 14							
	Bit 7 (MSB)	Bit 6	Bit 5	Bit 4	Bit 3	Bit 2	Bit 1	Bit 0 (LSB)
Reg. 115	NC	NC	NC	K850	K849	K848	K847	K846
				Bus 9	Bus 6	Bus 5	Bus 4	Bus 2

Control/ Status Register	Matrix Bus 'C' Output 15							
	Bit 7 (MSB)	Bit 6	Bit 5	Bit 4	Bit 3	Bit 2	Bit 1	Bit 0 (LSB)
Reg. 116	NC	NC	NC	K855	K854	K853	K852	K851
				Bus 0	Bus 6	Bus 5	Bus 4	Bus 2

Control/ Status Register	Matrix Bus 'C' Output 16							
	Bit 7 (MSB)	Bit 6	Bit 5	Bit 4	Bit 3	Bit 2	Bit 1	Bit 0 (LSB)
Reg. 117	NC	NC	NC	K860	K859	K858	K857	K856
				Bus 0	Bus 7	Bus 5	Bus 4	Bus 2

Control/ Status Register	Matrix Bus 'C' Output 17							
	Bit 7 (MSB)	Bit 6	Bit 5	Bit 4	Bit 3	Bit 2	Bit 1	Bit 0 (LSB)
Reg. 118	NC	NC	NC	K865	K864	K863	K862	K861
				Bus 9	Bus 7	Bus 5	Bus 4	Bus 2

Control/ Status Register	Matrix Bus 'C' Output 18							
	Bit 7 (MSB)	Bit 6	Bit 5	Bit 4	Bit 3	Bit 2	Bit 1	Bit 0 (LSB)
Reg. 119	NC	NC	NC	K870	K869	K868	K867	K866
				Bus 8	Bus 7	Bus 5	Bus 4	Bus 2

Control/ Status Register	Matrix Bus 'C' Output 19							
	Bit 7 (MSB)	Bit 6	Bit 5	Bit 4	Bit 3	Bit 2	Bit 1	Bit 0 (LSB)
Reg. 120	NC	NC	NC	K875	K874	K873	K872	K871
				Bus 0	Bus 5	Bus 4	Bus 3	Bus 2

Control/ Status Register	Matrix Bus 'C' Output 20							
	Bit 7 (MSB)	Bit 6	Bit 5	Bit 4	Bit 3	Bit 2	Bit 1	Bit 0 (LSB)
Reg. 121	NC	NC	NC	K880	K879	K878	K877	K876
				Bus 0	Bus 8	Bus 6	Bus 3	Bus 2

Control/ Status Register	Matrix Bus 'C' Output 21							
	Bit 7 (MSB)	Bit 6	Bit 5	Bit 4	Bit 3	Bit 2	Bit 1	Bit 0 (LSB)
Reg. 122	NC	NC	NC	K885	K884	K883	K882	K881
				Bus 9	Bus 6	Bus 5	Bus 3	Bus 2

Control/ Status Register	Matrix Bus 'C' Output 22							
	Bit 7 (MSB)	Bit 6	Bit 5	Bit 4	Bit 3	Bit 2	Bit 1	Bit 0 (LSB)
Reg. 123	NC	NC	NC	K890	K889	K888	K887	K886
				Bus 9	Bus 8	Bus 5	Bus 3	Bus 2

Control/ Status Register	Matrix Bus 'C' Output 23							
	Bit 7 (MSB)	Bit 6	Bit 5	Bit 4	Bit 3	Bit 2	Bit 1	Bit 0 (LSB)
Reg. 124	NC	NC	NC	K895	K894	K893	K892	K891
				Bus 8	Bus 7	Bus 5	Bus 3	Bus 2

Control/ Status Register	Matrix Bus 'C' Output 24							
	Bit 7 (MSB)	Bit 6	Bit 5	Bit 4	Bit 3	Bit 2	Bit 1	Bit 0 (LSB)
Reg. 125	NC	NC	NC	K900	K899	K898	K897	K896
				Bus 9	Bus 7	Bus 5	Bus 3	Bus 2

Matrix Load Configuration

Each matrix has two loads that can be configured as a pull-up or pull-down. Each load has 5 relay pairs used to select the load value and set it as a pull-up or pull-down. The two loads can be used in conjunction to form a pull-up/pull-down load.

Once configured, each load can be tied to one of the ten buss signals. This is accomplished using 10 relays, one for each buss signal. Care should be taken that only one buss/load relay is activated at any one time. This assures that buss signals are not shorted together. Both loads can be tied to the same buss signal to form a pull-up/pull-down load.

The following tables illustrate the activation of the corresponding relays to form pull-up or pull-down loads for each of the three matrices. For the following tables, Kxxx is the reference designator of the relay used while the '1' or '0' is the state of the relay activation bit written in the corresponding register.

Table 3-3, Matrix Load Selection

Matrix A "Load Selection"			
Load 1		Load 2	
50 Ohm	K186=1	50 Ohm	K196=1
Pull-up	K181=1	Pull-up	K191=1
Pull-down	K181=0	Pull-down	K191=0
75 Ohm	K187=1	75 Ohm	K197=1
Pull-up	K182=1	Pull-up	K192=1
Pull-down	K182=0	Pull-down	K192=0
100 Ohm	K188=1	100 Ohm	K198=1
Pull-up	K183=1	Pull-up	K193=1
Pull-down	K183=0	Pull-down	K193=0
500 Ohm	K189=1	500 Ohm	K199=1
Pull-up	K184=1	Pull-up	K194=1
Pull-down	K184=0	Pull-down	K194=0
1K Ohm	K190=1	1K Ohm	K200=1
Pull-up	K185=1	Pull-up	K195=1
Pull-down	K185=0	Pull-down	K195=0

Matrix A “Bus/Load Selection”			
Load 1		Load 2	
Buss 0	K201=1	Buss 0	K211=1
Buss 1	K202=1	Buss 1	K212=1
Buss 2	K203=1	Buss 2	K213=1
Buss 3	K204=1	Buss 3	K214=1
Buss 4	K205=1	Buss 4	K215=1
Buss 5	K206=1	Buss 5	K216=1
Buss 6	K207=1	Buss 6	K217=1
Buss 7	K208=1	Buss 7	K218=1
Buss 8	K209=1	Buss 8	K219=1
Buss 9	K210=1	Buss 9	K220=1

Matrix B “Load Selection”			
Load 1		Load 2	
50 Ohm	K226=1	50 Ohm	K236=1
Pull-up	K221=1	Pull-up	K231=1
Pull-down	K221=0	Pull-down	K231=0
75 Ohm	K227=1	75 Ohm	K237=1
Pull-up	K222=1	Pull-up	K232=1
Pull-down	K222=0	Pull-down	K232=0
100 Ohm	K228=1	100 Ohm	K238=1
Pull-up	K223=1	Pull-up	K233=1
Pull-down	K223=0	Pull-down	K233=0
500 Ohm	K229=1	500 Ohm	K239=1
Pull-up	K224=1	Pull-up	K234=1
Pull-down	K224=0	Pull-down	K234=0
1K Ohm	K230=1	1K Ohm	K240=1
Pull-up	K225=1	Pull-up	K235=1
Pull-down	K225=0	Pull-down	K235=0

Matrix B “Bus/Load Selection”			
Load 1		Load 2	
Buss 0	K241=1	Buss 0	K251=1
Buss 1	K242=1	Buss 1	K252=1
Buss 2	K243=1	Buss 2	K253=1
Buss 3	K244=1	Buss 3	K254=1
Buss 4	K245=1	Buss 4	K255=1
Buss 5	K246=1	Buss 5	K256=1
Buss 6	K247=1	Buss 6	K257=1
Buss 7	K248=1	Buss 7	K258=1
Buss 8	K249=1	Buss 8	K259=1
Buss 9	K250=1	Buss 9	K260=1

Matrix C “Load Selection”			
Load 1		Load 2	
50 Ohm	K266=1	50 Ohm	K276=1
Pull-up	K261=1	Pull-up	K271=1
Pull-down	K261=0	Pull-down	K271=0
75 Ohm	K267=1	75 Ohm	K277=1
Pull-up	K262=1	Pull-up	K272=1
Pull-down	K262=0	Pull-down	K272=0
100 Ohm	K268=1	100 Ohm	K278=1
Pull-up	K263=1	Pull-up	K273=1
Pull-down	K263=0	Pull-down	K273=0
500 Ohm	K269=1	500 Ohm	K279=1
Pull-up	K264=1	Pull-up	K274=1
Pull-down	K264=0	Pull-down	K274=0
1K Ohm	K270=1	1K Ohm	K280=1
Pull-up	K265=1	Pull-up	K275=1
Pull-down	K265=0	Pull-down	K275=0

Matrix C “Bus/Load Selection”			
Load 1		Load 2	
Buss 0	K281=1	Buss 0	K291=1
Buss 1	K282=1	Buss 1	K292=1
Buss 2	K283=1	Buss 2	K293=1
Buss 3	K284=1	Buss 3	K294=1
Buss 4	K285=1	Buss 4	K295=1
Buss 5	K286=1	Buss 5	K296=1
Buss 6	K287=1	Buss 6	K297=1
Buss 7	K288=1	Buss 7	K298=1
Buss 8	K289=1	Buss 8	K299=1
Buss 9	K290=1	Buss 9	K300=1

Appendix A

LOGICAL RELAY LAYOUT

1260-43 Layout Legend

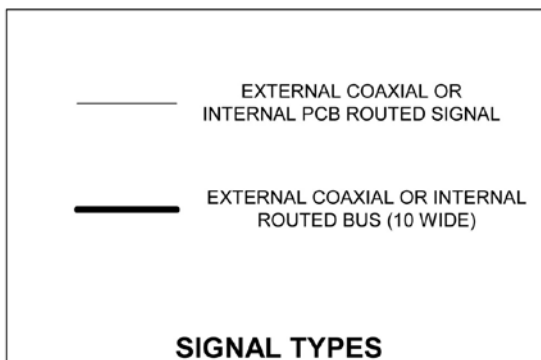
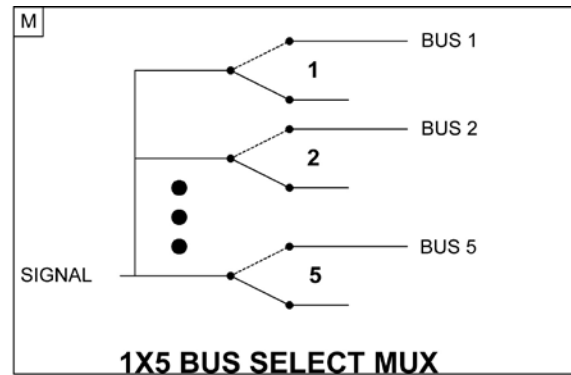
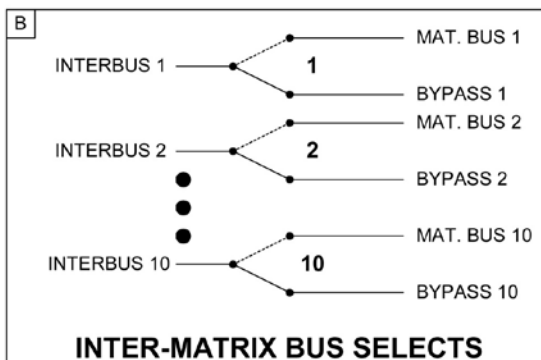
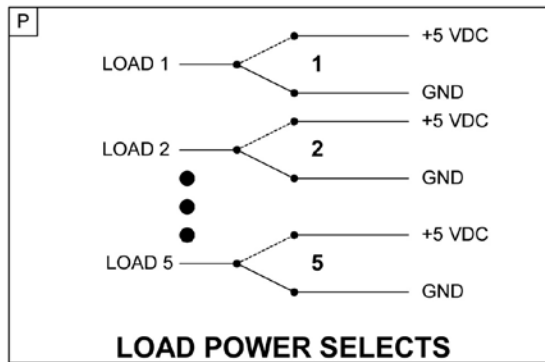
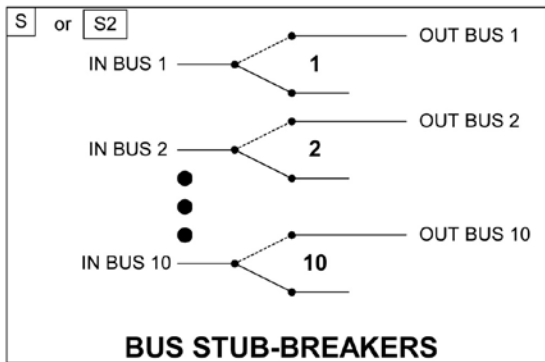
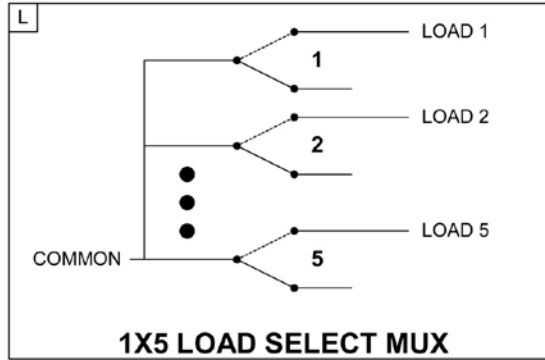
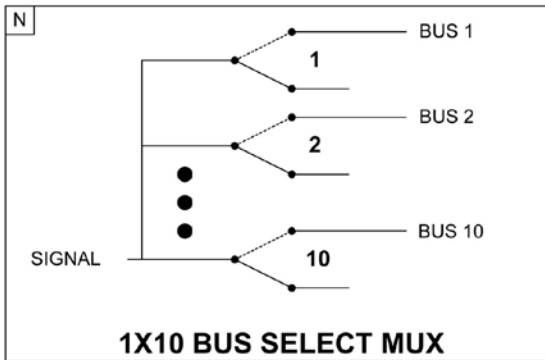

This page was left intentionally blank.

Appendix B

1260-43 RELAY LAYOUT
